

## EnOcean Serial Protocol 3 (ESP3)

V1.17 / Aug 02, 2011



## Content

<b>1</b>	<b>EnOcean Serial Protocol 3 (ESP3)</b>	<b>4</b>
1.1	Terms & Abbreviations	6
1.2	Introduction	7
1.3	Packet structure	8
1.4	Upward compatibility	9
1.5	UART framing	10
1.6	UART synchronization (packet detection)	10
1.6.1	Packet description	11
1.6.2	Packet types	11
1.6.3	Direction of packet types	12
1.6.4	ESP3 Timeout	12
1.7	Packet Type 1: RADIO	13
1.7.1	Packet structure	13
1.7.2	Radio variants (examples)	14
1.8	Packet Type 2: RESPONSE	15
1.8.1	Packet structure	15
1.8.2	List of Return Codes	15
1.8.3	Example: RET_OK (without response data)	15
1.9	Packet Type 3: RADIO_SUB_TEL	16
1.10	Packet Type 4: EVENT	17
1.10.1	Structure	17
1.10.2	List of EVENT Codes	17
1.10.3	Code 01: SA_RECLAIM_NOT_SUCCESSFUL	18
1.10.4	Code 02: SA_CONFIRM_LEARN	19
1.10.5	Code 03: SA_LEARN_ACK	20
1.10.6	Code 04: CO_READY	21
1.11	Packet Type 5: COMMON_COMMAND	22
1.11.1	Structure	22
1.11.2	List of COMMON_COMMAND Codes	22
1.11.3	Code 01: CO_WR_SLEEP	23
1.11.4	Code 02: CO_WR_RESET	23
1.11.5	Code 03: CO_RD_VERSION	24
1.11.6	Code 04: CO_RD_SYS_LOG	25
1.11.7	Code 05: CO_WR_SYS_LOG	26
1.11.8	Code 06: CO_WR_BIST	26
1.11.9	Code 07: CO_WR_IDBASE	27
1.11.10	Code 08: CO_RD_IDBASE	28
1.11.11	Code 09: CO_WR_REPEATER	29
1.11.12	Code 10: CO_RD_REPEATER	30
1.11.13	Code 11: CO_WR_FILTER_ADD	31
1.11.14	Code 12: CO_WR_FILTER_DEL	33
1.11.15	Code 13: CO_WR_FILTER_DEL_ALL	33

1.11.16	Code 14: CO_WR_FILTER_ENABLE .....	34
1.11.17	Code 15: CO_RD_FILTER.....	35
1.11.18	Code 16: CO_WR_WAIT_MATURITY.....	36
1.11.19	Code 17: CO_WR_SUBTEL .....	36
1.11.20	Code 18: CO_WR_MEM .....	37
1.11.21	Code 19: CO_RD_MEM .....	38
1.11.22	Code 20: CO_RD_MEM_ADDRESS .....	39
1.11.23	Code 21: CO_RD_SECURITY .....	40
1.11.24	Code 22: CO_WR_SECURITY .....	41
1.12	Packet Type 6: SMART_ACK_COMMAND .....	42
1.12.1	Structure .....	42
1.12.2	List of SMART ACK Codes .....	42
1.12.3	Code 01: SA_WR_LEARNMODE .....	43
1.12.4	Code 02: SA_RD_LEARNMODE .....	44
1.12.5	Code 03: SA_WR_LEARNCONFIRM .....	45
1.12.6	Code 04: SA_WR_CLIENTLEARNRQ .....	46
1.12.7	Code 05: SA_WR_RESET .....	47
1.12.8	Code 06: SA_RD_LEARNEDCLIENTS .....	48
1.12.9	Code 07: SA_WR_RECLAIMS .....	49
1.12.10	Code 08: SA_WR_POSTMASTER.....	49
1.13	Packet Type 7: REMOTE_MAN_COMMAND .....	50
1.13.1	Structure .....	50
1.13.2	Description .....	50
<b>2</b>	<b>Appendix .....</b>	<b>52</b>
2.1	ESP3 Data flow sequences .....	52
2.1.1	Client data request.....	52
2.1.2	Teach IN via VLL.....	52
2.1.3	Teach IN via Smart Ack .....	53
2.1.4	Teach IN via Smart Ack incl. repeater .....	53
2.2	ESP3 telegram examples .....	54
2.2.1	Packet: Radio VLD.....	54
2.2.2	Packet: CO_WR_SLEEP .....	54
2.2.3	Packet: CO_WR_RESET .....	54
2.2.4	Packet: CO_RD_IDBASE.....	54
2.2.5	Packet: REMOTE_MAN_COMMAND.....	54
2.3	CRC8 calculation .....	55
2.4	UART Synchronization (example c-code) .....	56
2.4.1	ESP3 Packet Structure .....	56
2.4.2	Get ESP3 Packet .....	56
2.4.3	Send ESP3 Packet .....	60

## 1 EnOcean Serial Protocol 3 (ESP3)

### REVISION HISTORY

The following major modifications and improvements have been made to the first version of this document:

No.	Major Changes	Date	Who
1.0	First Version		
1.1	Corrections, added uses cases		
1.2	Added small correction in CMD_SA_LEARNDEVICE command.		
1.2	Reworked improved protocol		
1.3	Removed SMACK comments – rework needed		
1.4	Document Reviewed, performance measurements moved to EO3000I_API		
1.5	Added PacketType = 3		
1.6	Added types and defined commands		
1.7	New terms and definitions; extended description	2010-08-31	ap, op, jh
1.8	Modifications	2010-09-07	ap, op
1.9	Extracted from system spec document, removed internal info	2010-09-15	ASt
1.10	1 <sup>st</sup> review	2010-09-28	op
1.11	2 <sup>nd</sup> review (notes ap, mf)	2010-10-11	op
1.12	Minor modifications	2010-10-27	nm, op
1.13	Minor modifications	2010-11-03	nm, op
1.14	New event: CO_READY	2010-12-10	op
1.15	New optional data in CO_RD_IDBASE	2011-02-28	wh,ap
1.16	Corrected wrong CRC8D in CO_WR_RESET example Changed the REMOTE_MAN_COMMAND	2011-06-14	jh
1.17	Examples added for CO_WR_FILTER_ADD	2011-08-02	mho, wh

**Published by EnOcean GmbH, Kolpingring 18a, 82041 Oberhaching, Germany  
 www.enocean.com, info@enocean.com, phone ++49 (89) 6734 6890**

© EnOcean GmbH  
 All Rights Reserved

## EnOcean Serial Protocol 3 (ESP3)

**Important!**

This information describes the type of component and shall not be considered as assured characteristics. No responsibility is assumed for possible omissions or inaccuracies. Circuitry and specifications are subject to change without notice. For the latest product specifications, refer to the EnOcean website: <http://www.enocean.com>.

As far as patents or other rights of third parties are concerned, liability is only assumed for modules, not for the described applications, processes and circuits.

EnOcean does not assume responsibility for use of modules described and limits its liability to the replacement of modules determined to be defective due to workmanship. Devices or systems containing RF components must meet the essential requirements of the local legal authorities.

The modules must not be used in any relation with equipment that supports, directly or indirectly, human health or life or with applications that can result in danger for people, animals or real value.

Components of the modules are considered and should be disposed of as hazardous waste. Local government regulations are to be observed.

Packing: Please use the recycling operators known to you. By agreement we will take packing material back if it is sorted. You must bear the costs of transport. For packing material that is returned to us unsorted or that we are not obliged to accept, we shall have to invoice you for any costs incurred.

## 1.1 Terms & Abbreviations

Term / Abbr.	Description
µC	Microcontroller (external)
API	Application Programming Interface
APP	Application
BIST	Built-in self-test
Choice	Unique identification of radio telegram types
Choice-EN	Addressed version of 'Choice' (EN = encapsulation)
CRC8	Cyclic redundancy check (CRC) or polynomial code checksum; CRC-8 = 9 bits polynomial lengths
CRC8D	CRC8 for Group 'Data' (incl. Optional Data)
CRC8H	CRC8 for Group 'Header'
Data	Payload of ESP3 packet
EEP	EnOcean Equipment Profile
ERP	EnOcean Radio Protocol
ESP3	EnOcean Serial Protocol V3
Field	Identifier of Data subset / element
Group	Part of ESP3 packet (header, data, optional data)
Host	ESP3 communication device
LSB	Least significant bit
Mailbox	Message filing of the Postmaster for each Smart Ack Sensor/Client
MSB	Most significant bit
Offset	Byte position pointer of packet
Packet	ESP3 data unit
Packet Type	Type of ESP3 Packet (Command, Event, Radio, ...)
PM	Postmaster
Postmaster	Includes multiple mailboxes for each Smart Ack Sensor/Client
RS-232	Telecommunication standard for serial binary single-ended data and control signals; ESP3 use only the minimal "3-wire" RS-232 connection consisting only of transmit data, receive data, and ground. The full facilities of RS-232 are not required.
RSSI	Received signal strength indication (dBm)
Smart Ack	EnOcean standard for energy-optimized bidirectional transmission
Subtelegram	Smallest unit of data in radio transmission, using orthogonal structure
Sync Byte	Identifier for ESP3 packet start
UART	Universal Asynchronous Receiver Transmitter

**1.2 Introduction**

This document specifies the EnOcean Serial Protocol 3.0 (ESP3). The ESP3 defines the serial communication between a host and EnOcean modules (based on Dolphin Platform). Hosts are external microcontrollers or PC's incl. software tools.

The physical interface between a host and a EnOcean RF module (UART) is a 3-wire connection (Rx, Tx, GND / software handshake / full-duplex), modelled on RS-232 serial interface.

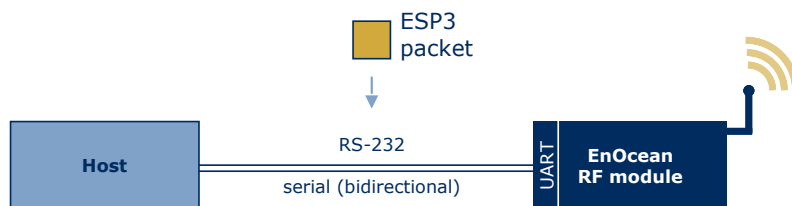

Figure 1

ESP3 enhances ESP2, adding future-proof structures and extending the data content. The new functional properties are:

- Transmission of the received radio signal strength, and number of the received subtelegrams
- Future requirements can be realized flexibly with the packet group "Optional Data", without violating the compatibility
- Improved data security and consistency by CRC8 Data verification
- Higher reliable ESP3 packet detection at serial byte stream
- Approximately seven-time higher baud rate

The ESP2/3 differences in summary:

	ESP 2.0	ESP 3.0
Subtelegram count	--	•
Receive signal strength (RSSI)	--	•
Upward compatible with 'Optional Data'	--	•
Data verification	Checksum	CRC8
UART Synchronization (packet detection)	2 bytes	6 bytes
Max. number of ESP packet types	8	256
Types of data	Radio, Command	Any type of data
Max. size of transferred data	28 bytes	65535 bytes
Communication speed	9600 baud	57600 baud

Table 1

### 1.3 Packet structure

ESP3 is a Point-to-Point protocol with a packet data structure. This principle encapsulates actual user data (payload), Command, Event or Response messages.

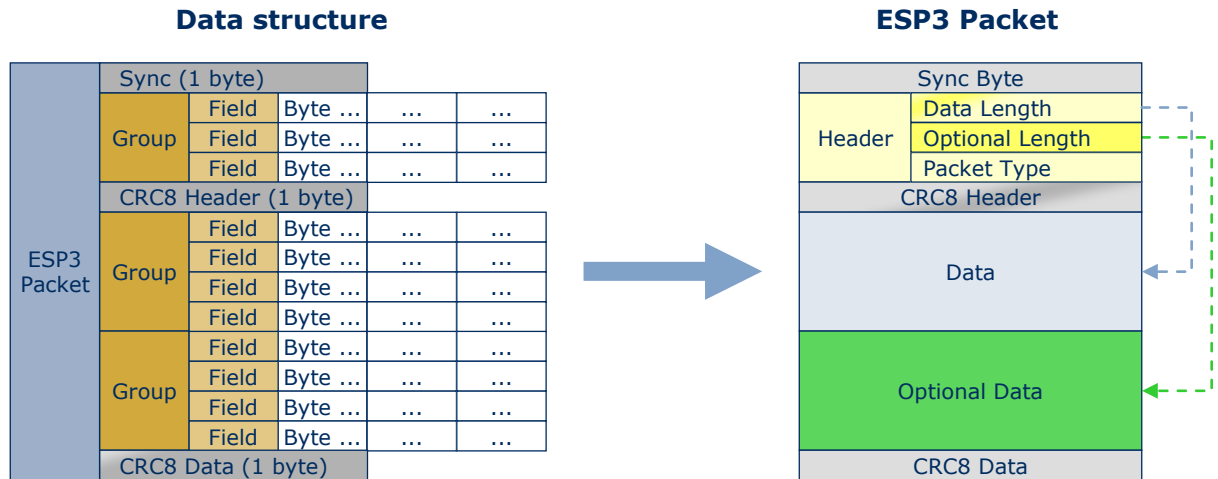

Figure 2

Every ESP3 packet consists of Header, Data and Optional Data.

The packet (frame) is divided into: Sync.-Byte (start), CRC8 for Header and CRC8 for Data (incl. Optional Data).

Every group consists of Fields, each with 1 or x bytes.

The ESP3 Header consists of the Fields:

- Data Length (number of bytes of the group Data)
- Optional Length (number of bytes of the group Optional Data)
- Packet Type (RADIO, RESPONSE, EVENT, COMMAND ...)



#### 1.4 Upward compatibility

The ESP3 protocol is defined as a specific structure of Sync.-Byte, Header & CRC8, which should not be changed in future versions.

For each type of packet the content and the length of DATA is different.

Today's applications have to be compliant with later versions of the ESP3 protocol ensuring an upwards compatibility.

New software applications or devices might require the definition of new types of packet.

Existing packet types may be modified only via the field OPTIONAL\_DATA. The field DATA is not to be changed.

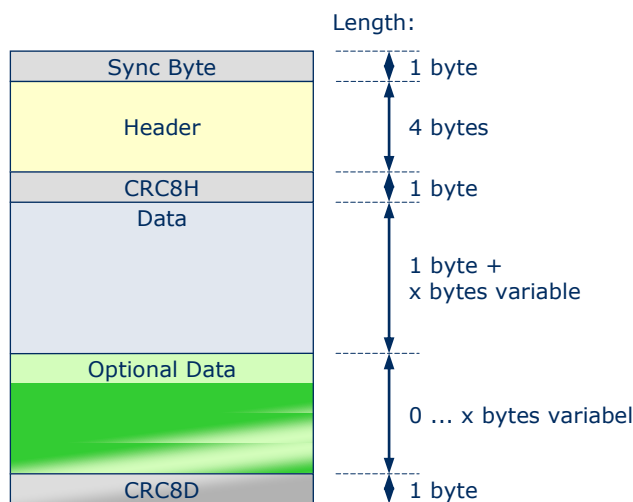

Figure 3

Existing devices will react as follows:

- Unknown packet types are confirmed with the RESPONSE message 'not supported' and will not be processed further.
- New fields in the Optional Data section of an existing packet type will be ignored; a RESPONSE message will not be sent.

Thus, backwards compatibility is secured.

EnOcean Serial Protocol 3 (ESP3)

**1.5 UART framing**

The UART of the EnOcean module has the framing: 8 data bits, no parity bit, one start bit (logical 0), one stop bit (logical 1). The line idle ( $\Delta$  neutral) is logical 1 (standard).

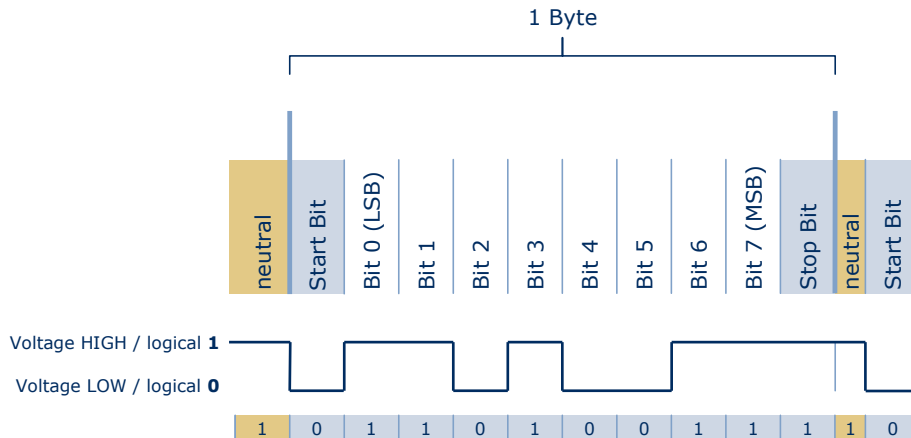

Figure 4

**1.6 UART synchronization (packet detection)**

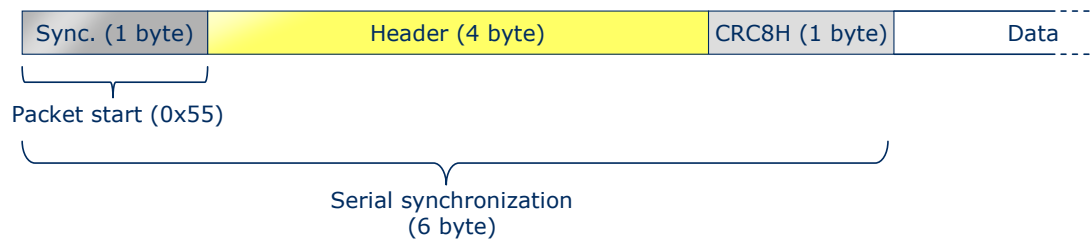

Figure 5

With ESP3 the reliability of the synchronization has been improved significantly:

As soon as a Sync.-Byte (value 0x55) is identified, the subsequent 4 byte-Header is compared with the corresponding CRC8H value.

If the result is a match the Sync.-Byte is correct. Consequently, the ESP3 packet is detected properly and the subsequent data will be passed.

If the Header does not match the CRC8H, the value 0x55 does not correspond to a Sync.-Byte. The next 0x55 within the data stream is picked and the verification is repeated.

The chapter 2.4 shows an example for a feasible implementation.

### 1.6.1 Packet description

Group	Offset	Size	Field	Value hex	Description
-	0	1	Sync. Byte	0x55	Serial synchronization byte; always set to 0x55
Header	1	2	Data Length	0xn <sup>nnn</sup>	Specifies how many bytes in DATA must be interpreted
	3	1	Optional Length	0xn <sup>n</sup>	Specifies how many bytes in OPTIONAL_DATA must be interpreted
	4	1	Packet Type	0xn <sup>n</sup>	Specifies the packet type of DATA, respectively OPTIONAL_DATA
-	5	1	CRC8H	0xn <sup>n</sup>	CRC8 Header byte; calculated checksum for bytes: DATA_LENGTH, OPTIONAL_LENGTH and TYPE
Data	6	x	...	...	Contains the actual data payload with topics: - RawData (e.g. 1:1 radio telegram) - Function codes + optional parameters - Return codes + optional parameters - Event codes x = variable length of DATA / byte number
Optional Data	6+x	y	...	...	Contains additional data that extends the field DATA; y = variable length of OPTIONAL_DATA
-	6+x+y	1	CRC8D	0xn <sup>n</sup>	CRC8 Data byte; calculated checksum for whole byte groups: DATA and OPTIONAL_DATA

Table 2

### 1.6.2 Packet types

Depending on the field [Packet Type] a different kind of packet is transmitted.

Type No.	Value hex	Name	Description
0	0x00	---	Reserved
1	0x01	RADIO	Radio telegram
2	0x02	RESPONSE	Response to any packet
3	0x03	RADIO_SUB_TEL	Radio subtelegram
4	0x04	EVENT	Event message
5	0x05	COMMON_COMMAND	Common command
6	0x06	SMART_ACK_COMMAND	Smart Ack command
7	0x07	REMOTE_MAN_COMMAND	Remote management command
8 ... 127	0x08 ... 7F	---	Reserved for EnOcean
128...255	0x80 ... FF	available	Manufacturer specific commands and messages

Table 3

### 1.6.3 Direction of packet types

The function and the properties of a packet type determine the direction of the ESP3 data traffic, and whether a RESPONSE message is required or not.

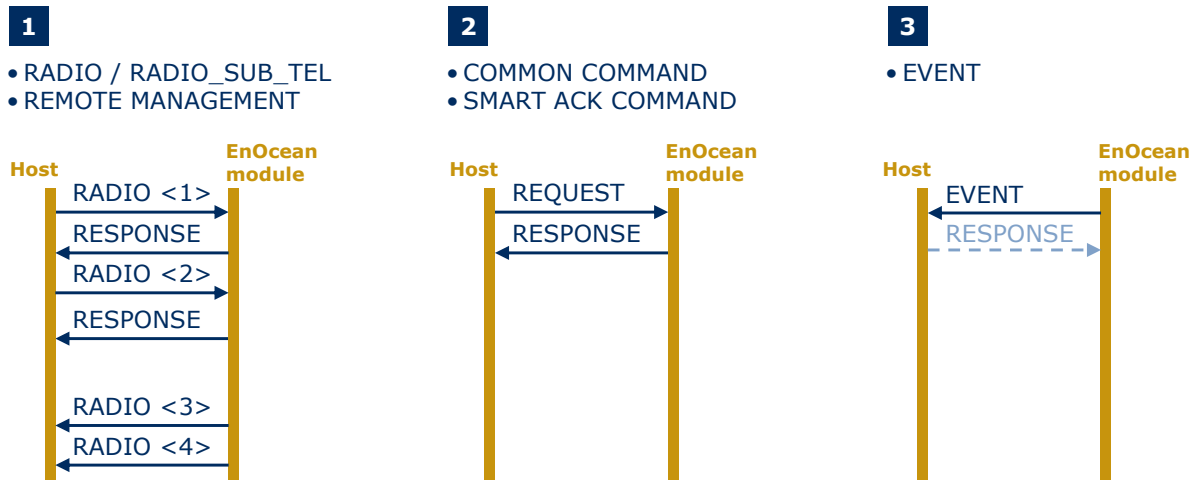

Figure 6

**Case 1:** ESP3 packets of the type RADIO, RADIO\_SUB\_TEL or REMOTE\_MAN pass bidirectionally across the serial interface. After sending a packet (host -> module) it is mandatory to wait for the RESPONSE message, only then the telegram is passed correctly via the radio interface. After receiving (module -> host) a packet no RESPONSE is required (see RADIO no. <3> and <4>).

**Case 2:** Only a host sends a ESP3 COMMAND (COMMON, SMART ACK) to an EnOcean module. Each REQUEST is answered with a RESPONSE message (OK, error, etc.). The reverse direction module-to-host is not possible.

**Case 3:** Only an EnOcean module sends an EVENT to a host. The type of the EVENT defines whether a RESPONSE message is required or not.

### 1.6.4 ESP3 Timeout

A timeout in an ESP3 packet is defined as soon as the time between two characters exceeds 100ms.

If the answer time between REQUEST/EVENT and RESPONSE exceeds 500ms a timeout is identified as well.

### 1.7 Packet Type 1: RADIO

#### 1.7.1 Packet structure

The radio telegram (raw data) is embedded into the ESP3 packet.  
 The actual user data (variable length) is a subset of the radio telegram.

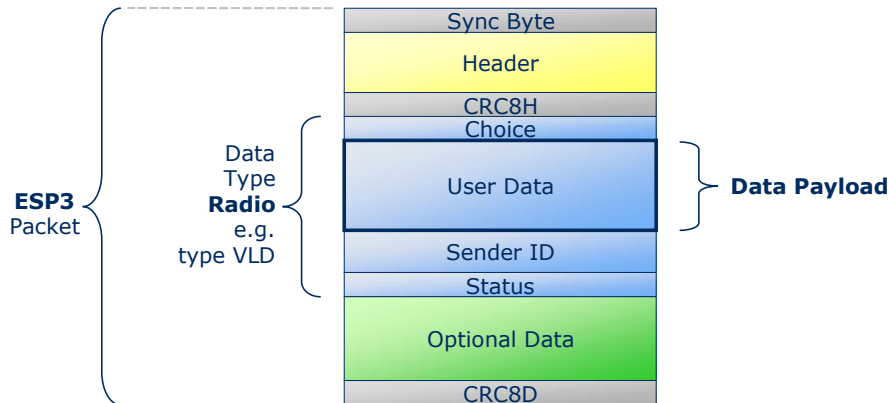

Figure 7

The following structure is applicable to all types of radio telegrams:

Group	Offset	Size	Field	Value hex	Description
-	0	1	Sync. Byte	0x55	
Header	1	2	Data Length	0xn <sup>nnn</sup>	Variable length of radio telegram
	3	1	Optional Length	0x07	7 fields fixed
	4	1	Packet Type	0x01	Radio = 1
-	5	1	CRC8H	0x <sup>nn</sup>	
Data	6	x	...	...	Radio telegram x = variable length / size
Optional Data	6+x	1	SubTelNum	0x <sup>nn</sup>	Number of subtelegram; Send: 3 / receive: 1 ... y
	7+x	4	Destination ID	0xn <sup>nnnnnnnn</sup>	Broadcast radio: FF FF FF FF ADT radio: Destination ID (= address)
	11+x	1	dBm	0x <sup>nn</sup>	Send case: FF Receive case: best RSSI value of all received subtelegrams (value decimal without minus)
	12+x	1	SecurityLevel	0x0 <sup>n</sup>	0 = telegram unencrypted n = type of encryption
-	13+x	1	CRC8D	0x <sup>nn</sup>	CRC8 <u>Data</u> byte; calculated checksum for whole byte groups: DATA and OPTIONAL_DATA

Table 4

### 1.7.2 Radio variants (examples)

Out of the numerous variants of the RADIO packet, described in other documents, only a few examples are described here. These examples describe the structure of DATA on the ESP3 interface. On the radio link specifically the ADT telegram has a different structure (e.g. Choice\_EN).

#### RADIO (VLD / VLL)

Group	Offset	Size	Field	Value hex	Description
Data	6	1	Choice	0xD2	Radio type VLD = D2, VLL = D4
	7	x	User Data	0xnn ... 0xnn	<b>1 ... 14</b> byte data payload
	7+x	4	Sender ID	0xn timer	Unique device sender ID
	11+x	1	Status	0xnn	Telegram control bits – used in case of repeating, switch telegram encapsulation, checksum type identification

Table 5

#### RADIO (ADT) Addressing Destination Telegram

Group	Offset	Size	Field	Value hex	Description
Data	6	1	Choice	0xD2	ADT Radio type, e.g. VLD = D2
	7	x	User Data	0xnn ... 0xnn	<b>1 ... 9</b> byte data payload
	7+x	4	Sender ID	0xn timer	Unique device sender ID
	11+x	1	Status	0xnn	Telegram control bits – used in case of repeating, switch telegram encapsulation, checksum type identification

Table 6

#### RADIO (4BS) / EEP profile 07-02-14

Group	Offset	Size	Field	Value hex	Description
Data	6	1	Choice	0xA5	Radio type 4BS
	7	1	Data Byte 3	0x00	Unused in this EEP profile
	8	1	Data Byte 2	0x00	Unused in this EEP profile
	9	1	Data Byte 1	0xnn	Temperature value 255 ... 0
	10	1	Data Byte 0	0b0000n000	DB_0.BIT 3 = Learn Bit Normal mode = 1 / Teach In = 0
	11	4	Sender ID	0xn timer	Unique device sender ID
	15	1	Status	0xnn	Telegram control bits – used in case of repeating, switch telegram encapsulation, checksum type identification

Table 7

## 1.8 Packet Type 2: RESPONSE

### 1.8.1 Packet structure

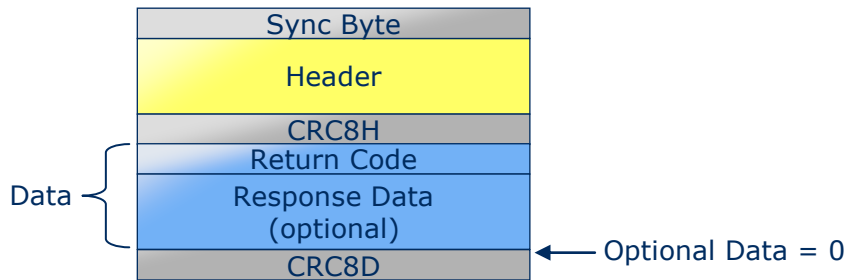

Figure 8

The properties of the preceding command and the re-delivered return-code determine whether optional response data are included, or only the return code itself.

### 1.8.2 List of Return Codes

Code	Name	Description
00	RET_OK	OK ... command is understood and triggered
01	RET_ERROR	There is an error occurred
02	RET_NOT_SUPPORTED	The functionality is not supported by that implementation
03	RET_WRONG_PARAM	There was a wrong parameter in the command
04	RET_OPERATION_DENIED	Example: memory access denied (code-protected)
> 128	---	Return codes greater than 0x80 are used for commands with special return information, not commonly useable.

Table 8

### 1.8.3 Example: RET\_OK (without response data)

Group	Offset	Size	Field	Value hex	Description
-	0	1	Sync. Byte	0x55	
Header	1	2	Data Length	0x0001	Data = 1 byte
	3	1	Optional Length	0x00	Optional Data = 0 byte
	4	1	Packet Type	0x02	RESPONSE = 2
-	5	1	CRC8H	0xnn	
Data	6	1	Return Code	0x00	RET_OK
-	7	1	CRC8D	0xnn	

Table 9

Specific variants of the response messages are described in the chapter of the command.

### 1.9 Packet Type 3: RADIO\_SUB\_TEL

This ESP3 packet type is functionality internal to EnOcean; it is applied for e.g. diagnosis or statistics. The packet design corresponds to the type RADIO. The content of the OPTIONAL\_DATA is altered slightly.

Group	Offset	Size	Field	Value hex	Description
-	0	1	Sync. Byte	0x55	
Header	1	2	Data Length	0xnxxx	Variable length of radio subtelegram
	3	1	Optional Length	0xnn	9 + x + 3*s bytes x = variable length radio subtelegram s = number of subtelegram
	4	1	Packet Type	0x03	RADIO_SUB_TEL = 3
-	5	1	CRC8H	0xnn	
Data	6	x	...	...	Radio telegram x = variable length / size
Optional Data	6+x	1	SubTelNum	0xnn	actual sequence number of subtelegrams (1 ... y); Repeated telegrams will be added
	7+x	4	Destination ID	0xxxxxxxx	Broadcast radio: FF FF FF FF ADT radio: Destination ID (= address)
	11+x	1	dBm	0xnn	Send case: FF Receive case: best RSSI value of all received subtelegrams (value decimal without minus)
	12+x	1	SecurityLevel	0x0n	0 = telegram unencrypted n = type of encryption
	13+x	2	TimeStamp	0xnxxx	Timestamp of 1 <sup>st</sup> subtelegram is the system timer tick [ms] (2 byte lower address)
	15+x	1	Tick SubTel		Relative time [ms] of each subtelegram in relation to the TimeStamp
	15+x +1*s	1	dBm SubTel		RSSI value of each subtelegram
	15+x +2*s	1	Status SubTel	0xnn	Telegram control bits of each subtelegram – used in case of repeating, switch telegram encapsulation, checksum type identification
-	15+x +3*s	1	CRC8D	0xnn	

Table 10

Every received subtelegram has the group **s** with fields in the order: Tick SubTel, dBm SubTel, Status SubTel (s = also number of subtelegram / multiplier to calculate the offset).



## 1.10 Packet Type 4: EVENT

### 1.10.1 Structure

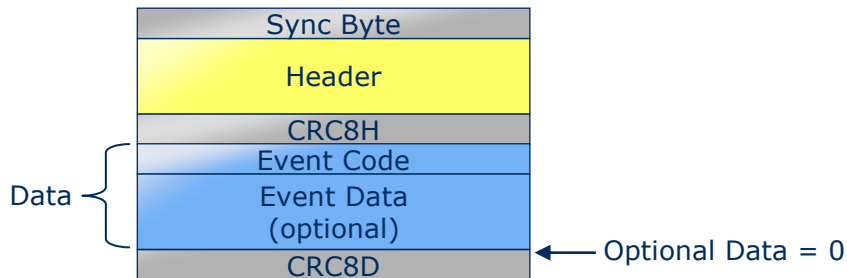

Figure 9

An EVENT is primarily a confirmation for processes and procedures, incl. specific data content. Events are currently used only by Smart Ack.

In the current version of ESP3 the type EVENT carries no optional data.

### 1.10.2 List of EVENT Codes

Code	Name	Description
01	SA_RECLAIM_NOT_SUCCESSFUL	Informs the backbone of a Smart Ack Client to not successful reclaim.
02	SA_CONFIRM_LEARN	Used for SMACK to confirm/discard learn in/out
03	SA_LEARN_ACK	Inform backbone about result of learn request
04	CO_READY	Inform backbone about about the readiness for operation

Table 11

## EnOcean Serial Protocol 3 (ESP3)

**1.10.3 Code 01: SA\_RECLAIM\_NOT\_SUCCESSFUL**

Function: Informs the backbone of a Smart Ack Client to not successful reclaim.

Group	Offset	Size	Field	Value hex	Description
-	0	1	Sync. Byte	0x55	
Header	1	2	Data Length	0x0001	1 byte
	3	1	Optional Length	0x00	0 byte
	4	1	Packet Type	0x04	EVENT = 4
-	5	1	CRC8H	0xnn	
Data	6	1	Event Code	0x01	SA_RECLAIM_NOT_SUCCESSFUL = 1
-	7	1	CRC8D	0xnn	

Table 12

Following described **RESPONSE** applies to return codes:

00: RET\_OK

01: RET\_ERROR

02: RET\_NOT\_SUPPORTED

03: RET\_WRONG\_PARAM

Group	Offset	Size	Field	Value hex	Description
-	0	1	Sync. Byte	0x55	
Header	1	2	Data Length	0x0001	1 byte
	3	1	Optional Length	0x00	0 byte
	4	1	Packet Type	0x02	RESPONSE = 2
-	5	1	CRC8H	0xnn	
Data	6	1	Return Code	0xnn	00, 01, 02, 03
-	7	1	CRC8D	0xnn	

Table 13

**1.10.4 Code 02: SA\_CONFIRM\_LEARN**

Function: Request to backbone controller how to handle the received learn request.

Group	Offset	Size	Field	Value hex	Description
-	0	1	Sync. Byte	0x55	
Header	1	2	Data Length	0x0011	17 bytes
	3	1	Optional Length	0x00	0 byte
	4	1	Packet Type	0x04	EVENT = 4
-	5	1	CRC8H	0xnn	
Data	6	1	Event Code	0x02	SA_CONFIRM_LEARN = 2
	7	1	Priority of the postmaster candidate	0xnn	Already post master 0b xxxx 1xxx Place for mailbox 0b xxxx x1xx Good RSSI 0b xxxx xx1x Local 0b xxxx xxx1
	8	1	2 <sup>2</sup> ... 2 <sup>0</sup> : Manufacturer ID 2 <sup>7</sup> ... 2 <sup>3</sup> : Res.	0b00000nnn	nnn = Most significant 3 bits of the Manufacturer ID 00000 = reserved
	9	1	Manufacturer ID	0xnn	Least significant bits of the Manufact. ID
	10	3	EEP	0xn timer	Code of used EEP profile
	13	1	RSSI	0xnn	Signal strength; Send case: FF Receive case: actual RSSI
	14	4	Postmaster Candidate ID	0xn timer	Device ID of the Post master candidate
	18	4	Smart Ack ClientID	0xn timer	This sensor would be Learn IN
-	22	1	Hop Count	0xnn	Numbers of repeater hop
-	23	1	CRC8D	0xnn	

Table 14

Following described **RESPONSE** applies to return code:

**00: RET\_OK**

Group	Offset	Size	Field	Value hex	Description
-	0	1	Sync. Byte	0x55	
Header	1	2	Data Length	0x0004	4 byte
	3	1	Optional Length	0x00	0 byte
	4	1	Packet Type	0x02	RESPONSE = 2
-	5	1	CRC8H	0xnn	
Data	6	1	Return Code	0x00	RET_OK = 0
	7	2	Response time	0xn timer	Response time for Smart Ack Client in ms in which the controller can prepare the data and send it to the postmaster. Only actual if learn return code is Learn IN
	9	1	Confirm code	0xnn	0x00 Learn IN 0x11 Discard Learn IN, EEP not accepted 0x12 Discard Learn IN, PM has no place for further mailbox 0x13 Discard Learn IN, Controller has no place for new sensor 0x14 Discard Learn IN, RSSI was not good enough 0x20 Learn OUT 0xFF Function not supported
	-	10	1	CRC8D	0xnn

Table 15

For **RESPONSE** with return codes: **01** RET\_ERROR, **02** RET\_NOT\_SUPPORTED, **03** RET\_WRONG\_PARAM is the structure described by the chapter: 1.8.3

### 1.10.5 Code 03: SA\_LEARN\_ACK

Function: Informs Smart Ack client about the result of a previous sent learn request.

Group	Offset	Size	Field	Value hex	Description
-	0	1	Sync. Byte	0x55	
Header	1	2	Data Length	0x0004	4 bytes
	3	1	Optional Length	0x00	0 byte
	4	1	Packet Type	0x04	EVENT = 4
-	5	1	CRC8H	0xnn	
Data	6	1	Event Code	0x03	SA_LEARN_ACK = 3
	7	2	Response time	0xnnnn	Response time for Smart Ack Client in ms in which the controller can prepare the data and send it to the postmaster. Only actual if learn return code is Learn IN
	9	1	Confirm code	0xnn	0x00 Learn IN 0x11 Discard Learn IN, EEP not accepted 0x12 Discard Learn IN, PM has no place for further MB 0x13 Discard Learn IN, Controller has no place for new sensor 0x14 Discard Learn IN, RSSI was not good enough 0x20 Learn OUT
-	10	1	CRC8D	0xnn	

Table 16

In this case, the following **RESPONSE** message gives the return codes:

**00** RET\_OK  
**02** RET\_NOT\_SUPPORTED  
**03** RET\_WRONG\_PARAM

Since no additional data are included, that have to be described, the standard RESPONSE structure is described in chapter 1.8.3

**1.10.6 Code 04: CO\_READY**

Function: Informs backbone about the readiness for operation.

Group	Offset	Size	Field	Value hex	Description
-	0	1	Sync. Byte	0x55	
Header	1	2	Data Length	0x0004	2 bytes
	3	1	Optional Length	0x00	0 byte
	4	1	Packet Type	0x04	EVENT = 4
-	5	1	CRC8H	0xnn	
Data	6	1	Event Code	0x04	CO_READY = 4
	7	1	Reset Cause	0xnn	<b>00</b> = Voltage supply drop or indicates that VDD > VON <b>01</b> = Reset caused by usage of the reset pin (is set also after downloading the program with the programmer) <b>02</b> = Watchdog timer counter reached the timer period <b>03</b> = Flywheel timer counter reached the timer period <b>04</b> = Parity error <b>05</b> = HW Parity error in the Internal or External Memory <b>06</b> = A memory request from the CPU core does not correspond to any valid memory location. This error may be caused by a S/W malfunction. <b>07</b> = Wake-up pin 0 activated <b>08</b> = Wake-up pin 1 activated <b>09</b> = Unknown reset source - reset reason couldn't be detected
	8	1	CRC8D	0xnn	

Table 17

This EVENT does not require any RESPONSE message.

## 1.11 Packet Type 5: COMMON\_COMMAND

### 1.11.1 Structure

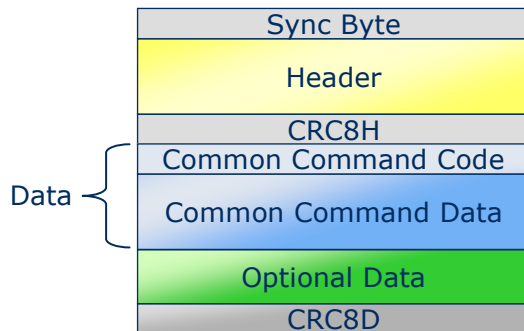

Figure 10

### 1.11.2 List of COMMON\_COMMAND Codes

Code	Function Name	Description
01	CO_WR_SLEEP	Order to enter in energy saving mode
02	CO_WR_RESET	Order to reset the device
03	CO_RD_VERSION	Read the device (SW) version / (HW) version, chip ID etc.
04	CO_RD_SYS_LOG	Read system log from device databank
05	CO_WR_SYS_LOG	Reset System log from device databank
06	CO_WR_BIST	Perform Flash BIST operation
07	CO_WR_IDBASE	Write ID range base number
08	CO_RD_IDBASE	Read ID range base number
09	CO_WR_REPEATER	Write Repeater Level off,1,2
10	CO_RD_REPEATER	Read Repeater Level off,1,2
11	CO_WR_FILTER_ADD	Add filter to filter list
12	CO_WR_FILTER_DEL	Delete filter from filter list
13	CO_WR_FILTER_DEL_ALL	Delete all filter
14	CO_WR_FILTER_ENABLE	Enable/Disable supplied filters
15	CO_RD_FILTER	Read supplied filters
16	CO_WR_WAIT_MATURITY	Waiting till end of maturity time before received radio telegrams will transmitted
17	CO_WR_SUBTEL	Enable/Disable transmitting additional subtelegram info
18	CO_WR_MEM	Write x bytes of the Flash, XRAM, RAM0 ....
19	CO_RD_MEM	Read x bytes of the Flash, XRAM, RAM0 ....
20	CO_RD_MEM_ADDRESS	Feedback about the used address and length of the config area and the Smart Ack Table
21	CO_RD_SECURITY	Read security information (level, keys)
22	CO_WR_SECURITY	Write security information (level, keys)

Table 18

### 1.11.3 Code 01: CO\_WR\_SLEEP

Function: Order to enter the energy saving mode.

Group	Offset	Size	Field	Value hex	Description
-	0	1	Sync. Byte	0x55	
Header	1	2	Data Length	0x0005	5 bytes
	3	1	Optional Length	0x00	0 byte
	4	1	Packet Type	0x05	COMMON_COMMAND = 5
-	5	1	CRC8H	0xnn	
Data	6	1	COMMAND Code	0x01	CO_WR_SLEEP = 1
	7	4	Deep sleep period	0x00nnnnnn	Period in 10 ms units 00000000 = default max. value = max. data range 00 FF FF FF (~ 46h); After waking up, the module generate an internal hardware reset
-	11	1	CRC8D	0xnn	

Table 19

In this case, the following **RESPONSE** message gives only the return codes:

00 RET\_OK

02 RET\_NOT\_SUPPORTED

Since no additional data are included which require description the standard RESPONSE structure is detailed in chapter 1.8.3

### 1.11.4 Code 02: CO\_WR\_RESET

Function: Order to reset the device.

Group	Offset	Size	Field	Value hex	Description
-	0	1	Sync. Byte	0x55	
Header	1	2	Data Length	0x0001	1 byte
	3	1	Optional Length	0x00	0 byte
	4	1	Packet Type	0x05	COMMON_COMMAND = 5
-	5	1	CRC8H	0xnn	
Data	6	1	COMMAND Code	0x02	CO_WR_RESET = 2
-	7	1	CRC8D	0xnn	

Table 20

In this case, the following **RESPONSE** message gives only the return codes:

01 RET\_ERROR

02 RET\_NOT\_SUPPORTED

Since no additional data are included which require description the standard RESPONSE structure is detailed in chapter 1.8.3

**1.11.5 Code 03: CO\_RD\_VERSION**

Function: Read the device SW version / HW version, chip-ID, etc.

Group	Offset	Size	Field	Value hex	Description
-	0	1	Sync. Byte	0x55	
Header	1	2	Data Length	0x0001	1 byte
	3	1	Optional Length	0x00	0 byte
	4	1	Packet Type	0x05	COMMON_COMMAND = 5
-	5	1	CRC8H	0xnn	
Data	6	1	COMMAND Code	0x03	CO_RD_VERSION = 3
-	7	1	CRC8D	0xnn	

Table 21

Following described **RESPONSE** applies to return code:

**00: RET\_OK**

Group	Offset	Size	Field	Value hex	Description
-	0	1	Sync. Byte	0x55	
Header	1	2	Data Length	0x0021	33 bytes
	3	1	Optional Length	0x00	0 byte
	4	1	Packet Type	0x02	RESPONSE = 2
-	5	1	CRC8H	0xnn	
Data	6	1	Return Code	0x00	RET_OK = 0
	7	4	APP version	0xnnnnnnnn	Application Byte 1: Main version Byte 2: Beta version Byte 3: Alpha version Byte 4: Build
	11	4	API version	0xnnnnnnnn	Application Programming Interface Byte 1: Main version Byte 2: Beta version Byte 3: Alpha version Byte 4: Build
	15	4	Chip ID	0xnnnnnnnn	Unique ID
	19	4	Chip Version	0xnnnnnnnn	Reserved for internal use
	23	16	App. description	char. ASCII	8 bit ASCII / 16 characters; Null-terminated string
-	39	1	CRC8D	0xnn	

Table 22

For **RESPONSE** with return code:

**02 RET\_NOT\_SUPPORTED** is the standard structure described by the chapter 1.8.3



**1.11.6 Code 04: CO\_RD\_SYS\_LOG**

Function: Read System Log from device databank.

Group	Offset	Size	Field	Value hex	Description
-	0	1	Sync. Byte	0x55	
Header	1	2	Data Length	0x0001	1 byte
	3	1	Optional Length	0x00	0 byte
	4	1	Packet Type	0x05	COMMON_COMMAND = 5
-	5	1	CRC8H	0xnn	
Data	6	1	COMMAND Code	0x04	CO_RD_SYS_LOG = 4
-	7	1	CRC8D	0xnn	

Table 23

Following described **RESPONSE** applies to return code:**00: RET\_OK**

Group	Offset	Size	Field	Value hex	Description
-	0	1	Sync. Byte	0x55	
Header	1	2	Data Length	0xn timer	1+x bytes
	3	1	Optional Length	0xnn	y bytes
	4	1	Packet Type	0x02	RESPONSE = 2
-	5	1	CRC8H	0xnn	
Data	6	1	Return Code	0x00	RET_OK = 0
	7	x	API Log entry 000	0xnn	Log entry 000 - xxx in DATA: Log counter of API
			API Log entry 001	0xnn	
			API Log entry 002	0xnn	
			...	...	
		...	...		
Optional Data	7+x	y	APP Log entry 000	0xnn	Log entry 000 - xxx in OPTIONAL_DATA: Log counter of APP
			APP Log entry 001	0xnn	
			APP Log entry 002	0xnn	
			...	...	
			...	...	
-	7+x+y	1	CRC8D	0xnn	

Table 24

After a reset, the counters starts with FF and decrement with each new EVENT down to 00 and will stopped. With a reset command the counter starts again with FF.

For **RESPONSE** with return code:**02** RET\_NOT\_SUPPORTED is the standard structure described by the chapter 1.8.3

### 1.11.7 Code 05: CO\_WR\_SYS\_LOG

Function: Reset System Log from device databank.

Group	Offset	Size	Field	Value hex	Description
-	0	1	Sync. Byte	0x55	
Header	1	2	Data Length	0x0001	1 byte
	3	1	Optional Length	0x00	0 byte
	4	1	Packet Type	0x05	COMMON_COMMAND = 5
-	5	1	CRC8H	0xnn	
Data	6	1	COMMAND Code	0x05	CO_WR_SYS_LOG = 5
-	7	1	CRC8D	0xnn	

Table 25

In this case, the following **RESPONSE** message gives only the return codes:

00 RET\_OK

02 RET\_NOT\_SUPPORTED

Since no additional data are included which require description the standard RESPONSE structure is detailed in chapter 1.8.3

### 1.11.8 Code 06: CO\_WR\_BIST

Function: Perform Flash BIST operation (Built-in-self-test).

Group	Offset	Size	Field	Value hex	Description
-	0	1	Sync. Byte	0x55	
Header	1	2	Data Length	0x0001	1 byte
	3	1	Optional Length	0x00	0 byte
	4	1	Packet Type	0x05	COMMON_COMMAND = 5
-	5	1	CRC8H	0xnn	
Data	6	1	COMMAND Code	0x06	CO_WR_BIST = 6
-	7	1	CRC8D	0xnn	

Table 26

Following described **RESPONSE** applies to return code:

00: RET\_OK

Group	Offset	Size	Field	Value hex	Description
-	0	1	Sync. Byte	0x55	
Header	1	2	Data Length	0x0002	2 bytes
	3	1	Optional Length	0x00	0 byte
	4	1	Packet Type	0x02	RESPONSE = 2
-	5	1	CRC8H	0xnn	
Data	6	1	Return Code	0x00	RET_OK = 0
	7	1	BIST result	0xnn	BIST OK = 0, BIST failed = other value
-	8	1	CRC8D	0xnn	

Table 27

For **RESPONSE** with return code:

02 RET\_NOT\_SUPPORTED is the standard structure described by the chapter 1.8.3

**1.11.9 Code 07: CO\_WR\_IDBASE**

Function: Write ID range base number.



**IMPORTANT:** This function can only be called 10 times to change the base ID. There is no possibility to reset this constraint. Also power off/on will not allow more than 10 changes!

Group	Offset	Size	Field	Value hex	Description
-	0	1	Sync. Byte	0x55	
Header	1	2	Data Length	0x0005	5 bytes
	3	1	Optional Length	0x00	0 byte
	4	1	Packet Type	0x05	COMMON_COMMAND = 5
-	5	1	CRC8H	0xnn	
Data	6	1	COMMAND Code	0x07	CO_WR_IDBASE = 7
	7	4	Base ID	0xFFnnnnnn	Range between 0xFF800000 and 0xFFFFFFFF80
-	11	1	CRC8D	0xnn	

Table 28

**RESPONSE:**

Group	Offset	Size	Field	Value hex	Description
-	0	1	Sync. Byte	0x55	
Header	1	2	Data Length	0x0001	1 byte
	3	1	Optional Length	0x00	0 byte
	4	1	Packet Type	0x02	RESPONSE = 2
-	5	1	CRC8H	0xnn	
Data	6	1	Return Code	0xnn	RET_OK = 0x00 RET_NOT_SUPPORTED = 0x02  FLASH_HW_ERROR = 0x82 The write/erase/verify process failed, the flash page seems to be corrupted  BASEID_OUT_OF_RANGE = 0x90  BASEID_MAX_REACHED = 0x91 (BaseID was changed 10 times, no more changes are allowed)
	7	1	CRC8D	0xnn	

Table 29

## EnOcean Serial Protocol 3 (ESP3)

**1.11.10 Code 08: CO\_RD\_IDBASE**

Function: Read ID range base number.

Group	Offset	Size	Field	Value hex	Description
-	0	1	Sync. Byte	0x55	
Header	1	2	Data Length	0x0001	1 byte
	3	1	Optional Length	0x00	0 byte
	4	1	Packet Type	0x05	COMMON_COMMAND = 5
-	5	1	CRC8H	0xnn	
Data	6	1	COMMAND Code	0x08	CO_RD_IDBASE = 8
-	7	1	CRC8D	0xnn	

Table 30

Following described **RESPONSE** applies to return code:**00: RET\_OK**

Group	Offset	Size	Field	Value hex	Description
-	0	1	Sync. Byte	0x55	
Header	1	2	Data Length	0x0005	5 bytes
	3	1	Optional Length	0x01	1 byte
	4	1	Packet Type	0x02	RESPONSE = 2
-	5	1	CRC8H	0xnn	
Data	6	1	Return Code	0x00	RET_OK = 0
	7	4	Base ID	0xFFnnnnnn	Range between 0xFF800000 and 0xFFFFFFFF80
Optional Data	8	1	Remaining write cycles for Base ID	0xnn	Remaining write cycles for Base ID
-	9	1	CRC8D	0xnn	

Table 31

For **RESPONSE** with return code:**02 RET\_NOT\_SUPPORTED** is the standard structure described by the chapter 1.8.3

**1.11.11 Code 09: CO\_WR\_REPEATER**

Function: Write Repeater Level OFF, 1, 2.

Group	Offset	Size	Field	Value hex	Description
-	0	1	Sync. Byte	0x55	
Header	1	2	Data Length	0x0003	3 bytes
	3	1	Optional Length	0x00	0 byte
	4	1	Packet Type	0x05	COMMON_COMMAND = 5
-	5	1	CRC8H	0xnn	
Data	6	1	COMMAND Code	0x09	CO_WR_REPEATER = 09
	7	1	REP_ENABLE	0xnn	OFF = 0, ON = 1
	8	1	REP_LEVEL	0xnn	When Repeater OFF must be 0, when ON then 1 for Level-1 , 2 for Level-2
-	9	1	CRC8D	0xnn	

Table 32

In this case, the following **RESPONSE** message gives only the return codes:

00 RET\_OK  
 02 RET\_NOT\_SUPPORTED  
 03 RET\_WRONG\_PARAM

Since no additional data are included which require description the standard RESPONSE structure is detailed in chapter 1.8.3

## EnOcean Serial Protocol 3 (ESP3)

**1.11.12 Code 10: CO\_RD\_REPEATER**

Function: Read Repeater Level OFF, 1, 2.

Group	Offset	Size	Field	Value hex	Description
-	0	1	Sync. Byte	0x55	
Header	1	2	Data Length	0x0001	1 byte
	3	1	Optional Length	0x00	0 byte
	4	1	Packet Type	0x05	COMMON_COMMAND = 5
-	5	1	CRC8H	0xnn	
Data	6	1	COMMAND Code	0x0A	CO_RD_REPEATER = 10
-	7	1	CRC8D	0xnn	

Table 33

Following described **RESPONSE** applies to return code:**00: RET\_OK**

Group	Offset	Size	Field	Value hex	Description
-	0	1	Sync. Byte	0x55	
Header	1	2	Data Length	0x0003	3 bytes
	3	1	Optional Length	0x00	0 byte
	4	1	Packet Type	0x02	RESPONSE = 2
-	5	1	CRC8H	0xnn	
Data	6	1	Return Code	0x00	RET_OK = 0
	7	1	REP_ENABLE	0xnn	OFF = 0, ON = 1
	8	1	REP_LEVEL	0xnn	Repeater OFF = 0, 1 for Level-1, 2 for Level-2
-	9	1	CRC8D	0xnn	

Table 34

For **RESPONSE** with return code:**02 RET\_NOT\_SUPPORTED** is the standard structure described by the chapter: 1.8.3

**1.11.13 Code 11: CO\_WR\_FILTER\_ADD**

Function: Add filter to filter list.

Group	Offset	Size	Field	Value hex	Description
-	0	1	Sync. Byte	0x55	
Header	1	2	Data Length	0x0007	7 bytes
	3	1	Optional Length	0x00	0 byte
	4	1	Packet Type	0x05	COMMON_COMMAND = 5
-	5	1	CRC8H	0xnn	
Data	6	1	COMMAND Code	0x0B	CO_WR_FILTER_ADD = 11
	7	1	Filter type	0xnn	Device ID = 0, Choice = 1, dBm = 2
	8	4	Filter value	0xnnnnnnnn	Value of filter function 'compare': - device ID - Choice no. radio telegram type - dBm value RSSI of radio telegram
	12	1	Filter kind	0xnn	Filter kind blocks = 0x00 Filter kind apply = 0x80
-	13	1	CRC8D	0xnn	

Table 35

In this case, the following **RESPONSE** message gives the return codes:

```
00 RET_OK
01 RET_ERROR (memory space full)
02 RET_NOT_SUPPORTED
03 RET_WRONG_PARAM
```

Since no additional data are included, that have to be described, the standard RESPONSE structure is described in chapter: 1.8.3

Some examples for filters:

```
//BLOCKS specified ID
Filter_type = 0x0 (ID)
Filter_value = 0x12345678
Filter_kind = 0x00 (block)
```

```
//BLOCKS all other IDs besides specified ID
Filter_type = 0x0 (ID)
Filter_value = 0x12345678
Filter_kind = 0x80 (apply)
```

```
//BLOCKS telegrams with specified CHOICE
Filter_type = 0x1 (CHOICE)
Filter_value = 0xA5 (4BS)
Filter_kind = 0x00 (block)
```

```
//BLOCKS all other telegrams besides telegrams with specified CHOICE
Filter_type = 0x1 (CHOICE)
Filter_value = 0xA5 (4BS)
Filter_kind = 0x80 (apply)
```

EnOcean Serial Protocol 3 (ESP3)

```
//BLOCKS signals weaker than -70dBm  
Filter_type = 0x2 (dBm)  
Filter_value = 0x00000046 (dec 70)  
Filter_kind = 0x00 (block)
```

```
//BLOCKS signals stronger than -70dBm  
Filter_type = 0x2 (dBm)  
Filter_value = 0x00000046 (dec 70)  
Filter_kind = 0x80 (apply)
```



**1.11.14 Code 12: CO\_WR\_FILTER\_DEL**

Function: Delete filter from filter list.

Group	Offset	Size	Field	Value hex	Description
-	0	1	Sync. Byte	0x55	
Header	1	2	Data Length	0x0006	6 bytes
	3	1	Optional Length	0x00	0 byte
	4	1	Packet Type	0x05	COMMON_COMMAND = 5
-	5	1	CRC8H	0xnn	
Data	6	1	COMMAND Code	0x0C	CO_WR_FILTER_DEL = 12
	7	1	Filter type	0xnn	Device ID = 0, Choice = 1, dBm = 2
	8	4	Filter value	0xnnnnnnnn	Value of filter function 'compare': - device ID - Choice no. radio telegram type - RSSI of radio telegram in dBm
-	12	1	CRC8D	0xnn	

Table 36

In this case, the following **RESPONSE** message gives the return codes:

00 RET\_OK  
 01 RET\_ERROR  
 02 RET\_NOT\_SUPPORTED  
 03 RET\_WRONG\_PARAM

Since no additional data are included which require description the standard RESPONSE structure is detailed in chapter: 1.8.3

**1.11.15 Code 13: CO\_WR\_FILTER\_DEL\_ALL**

Function: Delete all filters from filter list.

Group	Offset	Size	Field	Value hex	Description
-	0	1	Sync. Byte	0x55	
Header	1	2	Data Length	0x0001	1 byte
	3	1	Optional Length	0x00	0 byte
	4	1	Packet Type	0x05	COMMON_COMMAND = 5
-	5	1	CRC8H	0xnn	
Data	6	1	COMMAND Code	0x0D	CO_WR_FILTER_DEL = 13
-	7	1	CRC8D	0xnn	

Table 37

In this case, the following **RESPONSE** message gives only the return codes:

00 RET\_OK  
 02 RET\_NOT\_SUPPORTED

Since no additional data are included which require description the standard RESPONSE structure is detailed in chapter: 1.8.3

**1.11.16 Code 14: CO\_WR\_FILTER\_ENABLE**

Function: Enable/Disable all supplied filters.

Group	Offset	Size	Field	Value hex	Description
-	0	1	Sync. Byte	0x55	
Header	1	2	Data Length	0x0003	3 bytes
	3	1	Optional Length	0x00	0 byte
	4	1	Packet Type	0x05	COMMON_COMMAND = 5
-	5	1	CRC8H	0xnn	
Data	6	1	COMMAND Code	0x0E	CO_WR_FILTER_ENABLE = 14
	7	1	Filter ON/OFF	0x0n	All filter disable = 0 (OFF) All filter enable = 1 (ON)
	8	1	Filter Operator	0x0n	OR composition of filters = 0 AND composition of filters = 1
-	9	1	CRC8D	0xnn	

Table 38

In this case, the following **RESPONSE** message gives the return codes:

00 RET\_OK

02 RET\_NOT\_SUPPORTED

03 RET\_WRONG\_PARAM

Since no additional data are included which require description the standard RESPONSE structure is detailed in chapter: 1.8.3

**1.11.17 Code 15: CO\_RD\_FILTER**

Function: Read supplied filters.

Group	Offset	Size	Field	Value hex	Description
-	0	1	Sync. Byte	0x55	
Header	1	2	Data Length	0x0001	1 byte
	3	1	Optional Length	0x00	0 byte
	4	1	Packet Type	0x05	COMMON_COMMAND = 5
-	5	1	CRC8H	0xnn	
Data	6	1	COMMAND Code	0x0F	CO_RD_FILTER = 15
-	7	1	CRC8D	0xnn	

Table 39

Following described **RESPONSE** applies to return code:**00: RET\_OK**

Group	Offset	Size	Field	Value hex	Description
-	0	1	Sync. Byte	0x55	
Header	1	2	Data Length	0xnnnn	1 + 6*f bytes (f = number of filters)
	3	1	Optional Length	0x00	0 byte
	4	1	Packet Type	0x02	RESPONSE = 2
-	5	1	CRC8H	0xnn	
Data	6	1	Return Code	0x00	RET_OK = 0
	7	1	Filter type	0xnn	Device ID = 0, Choice = 1, dBm = 2
	7 +1*f	4	Filter value	0xnnnnnnnn	Value of filter function 'compare': - device ID - Choice no. radio telegram type - RSSI of radio telegram in dBm
	7 +5*f	1	Filter ON/OFF	0xnn	Filter disable = 0 (OFF) Filter enable = 1 (ON)
-	7 +6*f	1	CRC8D	0xnn	

Table 40

Every supplied filter has the group **f** with fields in the order: filter type, filter value, filter On/Off (f = also number of filters / multiplier to calculate the offset).

For **RESPONSE** with return code:**02 RET\_NOT\_SUPPORTED** is the standard structure described by the chapter 1.8.3

**1.11.18 Code 16: CO\_WR\_WAIT\_MATURITY**

Function: Waiting till end of maturity time before received radio telegrams will transmit.

Group	Offset	Size	Field	Value hex	Description
-	0	1	Sync. Byte	0x55	
Header	1	2	Data Length	0x0002	2 bytes
	3	1	Optional Length	0x00	0 byte
	4	1	Packet Type	0x05	COMMON_COMMAND = 5
-	5	1	CRC8H	0xnn	
Data	6	1	COMMAND Code	0x10	CO_WR_WAIT_MATURITY = 16
	7	1	Wait End Maturity	0xnn	0: Radio telegrams are send immediately 1: Radio telegrams are send after the maturity time is elapsed
-	8	1	CRC8D	0xnn	

Table 41

In this case, the following **RESPONSE** gives the return codes:

00 RET\_OK  
02 RET\_NOT\_SUPPORTED  
03 RET\_WRONG\_PARAM

Since no additional data are included which require description the standard RESPONSE structure is detailed in chapter 1.8.3

**1.11.19 Code 17: CO\_WR\_SUBTEL**

Function: Enable/Disable transmitting additional subtelegram info.

Group	Offset	Size	Field	Value hex	Description
-	0	1	Sync. Byte	0x55	
Header	1	2	Data Length	0x0002	2 bytes
	3	1	Optional Length	0x00	0 byte
	4	1	Packet Type	0x05	COMMON_COMMAND = 5
-	5	1	CRC8H	0xnn	
Data	6	1	COMMAND Code	0x11	CO_WR_SUBTEL = 17
	7	1	Enable	0xnn	Enable = 1 Disable = 0
-	8	1	CRC8D	0xnn	

Table 42

In this case, the following **RESPONSE** gives the return codes:

00 RET\_OK  
02 RET\_NOT\_SUPPORTED  
03 RET\_WRONG\_PARAM

Since no additional data are included which require description the standard RESPONSE structure is detailed in chapter 1.8.3

**1.11.20 Code 18: CO\_WR\_MEM**

Function: Write x bytes of the Flash, RAM0, DATA, IDATA, XDATA.

Group	Offset	Size	Field	Value hex	Description
-	0	1	Sync. Byte	0x55	
Header	1	2	Data Length	0xn timer	6 + x bytes
	3	1	Optional Length	0x00	0 byte
	4	1	Packet Type	0x05	COMMON_COMMAND = 5
-	5	1	CRC8H	0xnn	
Data	6	1	COMMAND Code	0x12	CO_WR_MEM = 18
	7	1	Memory type	0xnn	Flash 0x00 RAM 0 0x01 data RAM 0x02 idata RAM 0x03 xdata RAM 0x04
	8	4	Memory address	0xn timer	Start address to write
	12	x	Memory data	0xnn ... 0xnn	Data content to write ... ...
-	12+x	1	CRC8D	0xnn	

Table 43

In this case, the following **RESPONSE** gives the return codes:

00 RET\_OK

02 RET\_NOT\_SUPPORTED

03 RET\_WRONG\_PARAM (address outside range of values)

04 RET\_OPERATION\_DENIED (memory access denied / code-protected)

Since no additional data are included which require description the standard RESPONSE structure is detailed in chapter: 1.8.3

**1.11.21 Code 19: CO\_RD\_MEM**

Function: Read x bytes of the Flash, RAM0, DATA, IDATA, XDATA.

Group	Offset	Size	Field	Value hex	Description
-	0	1	Sync. Byte	0x55	
Header	1	2	Data Length	0xnn08	8 bytes
	3	1	Optional Length	0x00	0 byte
	4	1	Packet Type	0x05	COMMON_COMMAND = 5
-	5	1	CRC8H	0xnn	
Data	6	1	COMMAND Code	0x13	CO_RD_MEM = 19
	7	1	Memory type	0xnn	Flash 0x00 RAM 0 0x01 data RAM 0x02 idata RAM 0x03 xdata RAM 0x04
	8	4	Memory address	0xnnnnnnnn	Start address to read
	12	2	Data length	0xnnnn	Length to be read
-	14	1	CRC8D	0xnn	

Table 44

Following described **RESPONSE** applies to return code:

**00: RET\_OK**

Group	Offset	Size	Field	Value hex	Description
-	0	1	Sync. Byte	0x55	
Header	1	2	Data Length	0xnnnn	1 + x bytes
	3	1	Optional Length	0x00	0 byte
	4	1	Packet Type	0x02	RESPONSE = 2
-	5	1	CRC8H	0xnn	
Data	6	1	Return Code	0x00	RET_OK = 0
	7	x	Memory data	0xnn ... 0xnn	Of read memory contents ... ...
	-	7+x	1	CRC8D	0xnn

Table 45

For **RESPONSE** with return codes:

**02** RET\_NOT\_SUPPORTED

**03** RET\_WRONG\_PARAM (address outside range of values)

**04** RET\_OPERATION\_DENIED (memory access denied / code-protected)

is the standard structure described by the chapter 1.8.3

**1.11.22 Code 20: CO\_RD\_MEM\_ADDRESS**

Function: Feedback about the used address and length of the config area and the Smart Ack table.

Group	Offset	Size	Field	Value hex	Description
-	0	1	Sync. Byte	0x55	
Header	1	2	Data Length	0x0002	2 bytes
	3	1	Optional Length	0x00	0 byte
	4	1	Packet Type	0x05	COMMON_COMMAND = 5
-	5	1	CRC8H	0xnn	
Data	6	1	COMMAND Code	0x14	CO_RD_MEM_ADDRESS = 20
	7	1	Memory area	0xnn	Config area = 0 Smart Ack Table = 1 System error log = 2
-	8	1	CRC8D	0xnn	

Table 46

Following described **RESPONSE** applies to return code:

**00: RET\_OK**

Group	Offset	Size	Field	Value hex	Description
-	0	1	Sync. Byte	0x55	
Header	1	2	Data Length	0x000A	10 bytes
	3	1	Optional Length	0x00	0 byte
	4	1	Packet Type	0x02	RESPONSE = 2
-	5	1	CRC8H	0xnn	
Data	6	1	Return Code	0x00	RET_OK = 0
	7	1	Memory type	0xnn	Flash 0x00 RAM 0 0x01 data RAM 0x02 idata RAM 0x03 xdata RAM 0x04
	8	4	Memory address	0xnnnnnnnn	Start address of config area / Smart Ack table / system error log
	12	4	Memory length	0xnnnnnnnn	Data length of config area / Smart Ack table / system error log
-	16	1	CRC8D	0xnn	

Table 47

For **RESPONSE** with return codes:

**02** RET\_NOT\_SUPPORTED

**03** RET\_WRONG\_PARAM

**04** RET\_OPERATION\_DENIED (memory access denied / code-protected)

is the standard structure described by the chapter 1.8.3

**1.11.23 Code 21: CO\_RD\_SECURITY**

Function: Read security information (level, keys).

Group	Offset	Size	Field	Value hex	Description
-	0	1	Sync. Byte	0x55	
Header	1	2	Data Length	0x0001	1 byte
	3	1	Optional Length	0x00	0 byte
	4	1	Packet Type	0x05	COMMON_COMMAND = 5
-	5	1	CRC8H	0xnn	
Data	6	1	COMMAND Code	0x15	CO_RD_SECURITY = 21
-	7	1	CRC8D	0xnn	

Table 48

Following described **RESPONSE** applies to return code:

**00: RET\_OK**

Group	Offset	Size	Field	Value hex	Description
-	0	1	Sync. Byte	0x55	
Header	1	2	Data Length	0x000A	10 bytes
	3	1	Optional Length	0x00	0 byte
	4	1	Packet Type	0x02	RESPONSE = 2
-	5	1	CRC8H	0xnn	
Data	6	1	Return Code	0x00	RET_OK = 0
	7	1	SEC LEVEL	0x0n	Type no. of encryption
	8	4	KEY	0xnnnnnnnn	Security key
	12	4	Rolling Code	0x00000000	Reserved
-	16	1	CRC8D	0xnn	

Table 49

For **RESPONSE** with return code:

**02 RET\_NOT\_SUPPORTED** is the standard structure described by the chapter 1.8.3



**1.11.24 Code 22: CO\_WR\_SECURITY**

Function: Write security information (level, keys).

Group	Offset	Size	Field	Value hex	Description
-	0	1	Sync. Byte	0x55	
Header	1	2	Data Length	0x000A	10 bytes
	3	1	Optional Length	0x00	0 byte
	4	1	Packet Type	0x05	COMMON_COMMAND = 5
-	5	1	CRC8H	0xnn	
Data	6	1	COMMAND Code	0x16	CO_WR_SECURITY = 22
	7	1	SEC LEVEL	0x0n	Type no. of encryption
	8	4	KEY	0xnnyyyyyyy	Security key
	12	4	Rolling Code	0x00000000	Reserved
-	16	1	CRC8D	0xnn	

Table 50

In this case, the following **RESPONSE** gives the return codes:

00 RET\_OK

01 RET\_ERROR

02 RET\_NOT\_SUPPORTED

03 RET\_WRONG\_PARAM

Since no additional data are included which require description the standard RESPONSE structure is detailed in chapter 1.8.3

## 1.12 Packet Type 6: SMART\_ACK\_COMMAND

### 1.12.1 Structure

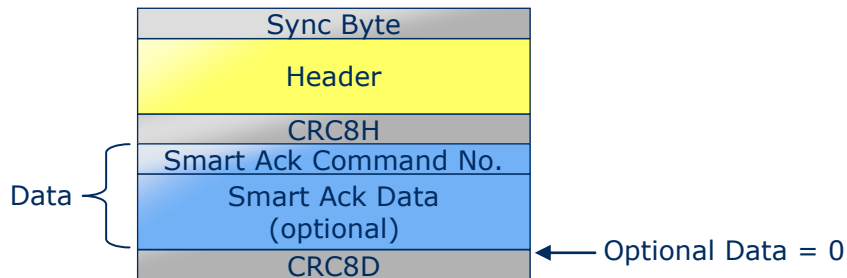

Figure 11

In the current version of ESP3 the packet type SMART\_ACK\_COMMAND carries no Optional Data.

### 1.12.2 List of SMART ACK Codes

Code	Function Name	Description
01	SA_WR_LEARNMODE	Set/Reset Smart Ack learn mode
02	SA_RD_LEARNMODE	Get Smart Ack learn mode state
03	SA_WR_LEARNCONFIRM	Used for Smart Ack to add or delete a mailbox of a client
04	SA_WR_CLIENTLEARNRQ	Send Smart Ack Learn request (Client)
05	SA_WR_RESET	Send reset command to a Smart Ack client
06	SA_RD_LEARNEDCLIENTS	Get Smart Ack learned sensors / mailboxes
07	SA_WR_RECLAIMS	Set number of reclaim attempts
08	SA_WR_POSTMASTER	Activate/Deactivate Post master functionality

Table 51

### 1.12.3 Code 01: SA\_WR\_LEARNMODE

Function: Enables or disables learn mode of Smart Ack Controller.

Group	Offset	Size	Field	Value hex	Description
-	0	1	Sync. Byte	0x55	
Header	1	2	Data Length	0x0007	7 bytes
	3	1	Optional Length	0x00	0 byte
	4	1	Packet Type	0x06	SMART_ACK_COMMAND = 6
-	5	1	CRC8H	0xnn	
Data	6	1	SMART_ACK Code	0x01	SA_WR_LEARNMODE = 1
	7	1	Enable	0x0n	Start Learnmode = 1 End Learnmode = 0
	8	1	Extended	0x0n	Simple Learnmode = 0 Advance Learnmode = 1 Advance Learnmode select Rep. = 2
	9	4	Timeout	0xnnnnnnnn	Time-Out for the learn mode in ms. When time is 0 then default period of 60'000 ms is used
-	13	1	CRC8D	0xnn	

Table 52

In this case, the following **RESPONSE** message gives the return codes:

00 RET\_OK

02 RET\_NOT\_SUPPORTED

03 RET\_WRONG\_PARAM

Since no additional data are included which require description the standard RESPONSE structure is detailed in chapter 1.8.3

#### 1.12.4 Code 02: SA\_RD\_LEARNMODE

Function: Reads the learnmode state of Smart Ack Controller.

Group	Offset	Size	Field	Value hex	Description
-	0	1	Sync. Byte	0x55	
Header	1	2	Data Length	0x0001	1 byte
	3	1	Optional Length	0x00	0 byte
	4	1	Packet Type	0x06	SMART_ACK_COMMAND = 6
-	5	1	CRC8H	0xnn	
Data	6	1	SMART_ACK Code	0x02	SA_RD_LEARNMODE = 2
-	7	1	CRC8D	0xnn	

Table 53

Following described **RESPONSE** applies to return code:

00: RET\_OK

Group	Offset	Size	Field	Value hex	Description
-	0	1	Sync. Byte	0x55	
Header	1	2	Data Length	0x0003	3 bytes
	3	1	Optional Length	0x00	0 byte
	4	1	Packet Type	0x02	RESPONSE = 2
-	5	1	CRC8H	0xnn	
Data	6	1	Return Code	0x00	RET_OK = 0
	7	1	Enable	0x0n	Learnmode not active = 0 Learnmode active = 1
	8	1	Extended	0x0n	Simple Learnmode = 0 Advance Learnmode = 1 Advance Learnmode select Rep. = 2
-	9	1	CRC8D	0xnn	

Table 54

For **RESPONSE** with return code:

02 RET\_NOT\_SUPPORTED

is the standard structure described by the chapter 1.8.3

**1.12.5 Code 03: SA\_WR\_LEARNCONFIRM**

Function: Send smart ack learn answer to modify mailbox at postmaster.

Group	Offset	Size	Field	Value hex	Description
-	0	1	Sync. Byte	0x55	
Header	1	2	Data Length	0x000C	12 bytes
	3	1	Optional Length	0x00	0 byte
	4	1	Packet Type	0x06	SMART_ACK_COMMAND = 6
-	5	1	CRC8H	0xnn	
Data	6	1	SMART_ACK Code	0x03	SA_WR_LEARNCONFIRM = 3
	7	2	Response time	0xnxxx	Response time for sensor in ms in which the controller can prepare the data and send it to the postmaster. Only actual, if learn return code is Learn IN.
	9	1	Confirm code	0xnn	Learn IN: 0x00 Learn OUT: 0x20
	10	4	Postmaster Candidate ID	0xnxxxxxxx	Device ID of the used Post master
	14	4	Smart Ack Client ID	0xnxxxxxxx	Device ID of the learned IN/OUT Smart Ack Client
-	18	1	CRC8D	0xnn	

Table 55

In this case, the following **RESPONSE** message gives only the return codes:

00 RET\_OK

02 RET\_NOT\_SUPPORTED

03 RET\_WRONG\_PARAM

Since no additional data are included which require description the standard RESPONSE structure is detailed in chapter 1.8.3

### 1.12.6 Code 04: SA\_WR\_CLIENTLEARNRQ

Function: Sends Smart Ack Learn Request telegram to Smart Ack Controller. This function will only be used in a Smart Ack Client.

Group	Offset	Size	Field	Value hex	Description
-	0	1	Sync. Byte	0x55	
Header	1	2	Data Length	0x0006	6 bytes
	3	1	Optional Length	0x00	0 byte
	4	1	Packet Type	0x06	SMART_ACK_COMMAND = 6
-	5	1	CRC8H	0xnn	
Data	6	1	SMART_ACK Code	0x04	SA_WR_CLIENTLEARNRQ = 4
	7	1	2 <sup>2</sup> ... 2 <sup>0</sup> : Manufacturer ID 2 <sup>7</sup> ... 2 <sup>3</sup> : Reserved	0b11111nnn	nnn = Most significant 3 bits of the Manufacturer ID 11111 = reserved / default values
	8	1	Manufacturer ID	0xnn	Least significant bits of the Manufacturer ID
	9	3	EEP	0xnnnnnn	EEP of the Smart Ack client, who wants to Teach IN.
-	12	1	CRC8D	0xnn	

Table 56

In this case, the following **RESPONSE** message gives the return codes:

00 RET\_OK

02 RET\_NOT\_SUPPORTED

03 RET\_WRONG\_PARAM

Since no additional data are included which require description the standard RESPONSE structure is detailed in chapter 1.8.3

## EnOcean Serial Protocol 3 (ESP3)

**1.12.7 Code 05: SA\_WR\_RESET**

Function: Send reset command to a Smart Ack Client.

Group	Offset	Size	Field	Value hex	Description
-	0	1	Sync. Byte	0x55	
Header	1	2	Data Length	0x0005	5 bytes
	3	1	Optional Length	0x00	0 byte
	4	1	Packet Type	0x06	SMART_ACK_COMMAND = 6
-	5	1	CRC8H	0xnn	
Data	6	1	SMART_ACK Code	0x05	SA_WR_RESET = 5
	7	4	Smart Ack Client ID	0xn timer	Device ID of the Smart Ack Client
-	11	1	CRC8D	0xnn	

Table 57

In this case, the following **RESPONSE** message gives the return codes:

00 RET\_OK

02 RET\_NOT\_SUPPORTED

03 RET\_WRONG\_PARAM

Since no additional data are included which require description the standard RESPONSE structure is detailed in chapter 1.8.3

**1.12.8 Code 06: SA\_RD\_LEARNEDCLIENTS**

Read mailbox information at the Post Master device, about all learned Smart Ack clients.

Group	Offset	Size	Field	Value hex	Description
-	0	1	Sync. Byte	0x55	
Header	1	2	Data Length	0x0001	1 byte
	3	1	Optional Length	0x00	0 byte
	4	1	Packet Type	0x06	SMART_ACK_COMMAND = 6
-	5	1	CRC8H	0xnn	
Data	6	1	SMART_ACK Code	0x06	SA_RD_LEARNEDCLIENTS = 6
-	7	1	CRC8D	0xnn	

Table 58

Following described **RESPONSE** applies to return code:

**00: RET\_OK**

Group	Offset	Size	Field	Value hex	Description
-	0	1	Sync. Byte	0x55	
Header	1	2	Data Length	0xnnnn	1 + 9*c bytes (c = number of clients)
	3	1	Optional Length	0x00	0 byte
	4	1	Packet Type	0x02	RESPONSE = 2
-	5	1	CRC8H	0xnn	
Data	6	1	Return Code	0x00	RET_OK = 0
	7	4	Smart Ack Client ID	0xnnnnnnnn	Device ID of the Smart Ack Client
	7 + 4*c	4	Postmaster ID	0xnnnnnnnn	Postmaster ID dedicated Smart Ack Client
	7 + 8*c	1	Mailbox index	0xnn	Internal counter of Post master (0x00 ... 0x0E)
-	7 + 9*c	1	CRC8D	0xnn	

} **c**

Table 59

Every learned Smart Ack Client has the group **c** with fields in the order: Controller ID, Smart Ack Client ID, Mailbox index (c = also number of clients / multiplier to calculate the offset).

For **RESPONSE** with return code:

**02 RET\_NOT\_SUPPORTED**

is the standard structure described by the chapter 1.8.3



**1.12.9 Code 07: SA\_WR\_RECLAIMS**

Function: Set the amount of reclaim tries in Smart Ack Client.

Group	Offset	Size	Field	Value hex	Description
-	0	1	Sync. Byte	0x55	
Header	1	2	Data Length	0x0002	2 bytes
	3	1	Optional Length	0x00	0 byte
	4	1	Packet Type	0x06	SMART_ACK_COMMAND = 6
-	5	1	CRC8H	0xnn	
Data	6	1	SMART_ACK Code	0x07	SA_WR_RECLAIMS = 7
	7	1	Reclaim count	0xnn	Presetting for the number of required reclaim tries
-	8	1	CRC8D	0xnn	

Table 60

In this case, the following **RESPONSE** message gives the return codes:

00 RET\_OK  
 02 RET\_NOT\_SUPPORTED  
 03 RET\_WRONG\_PARAM

Since no additional data are included which require description the standard RESPONSE structure is detailed in chapter 1.8.3

**1.12.10 Code 08: SA\_WR\_POSTMASTER**

Function: Enables/Disables postmaster function of device.

Group	Offset	Size	Field	Value hex	Description
-	0	1	Sync. Byte	0x55	
Header	1	2	Data Length	0x0002	2 bytes
	3	1	Optional Length	0x00	0 byte
	4	1	Packet Type	0x06	SMART_ACK_COMMAND = 6
-	5	1	CRC8H	0xnn	
Data	6	1	SMART_ACK Code	0x08	SA_WR_POSTMASTER = 8
	7	1	Mailbox count	0xnn	Amount of mailboxes available, 0 = disable post master functionality; Maximum 28 mailboxes can be created. This upper limit is for each firmware restricted and may be smaller.
-	8	1	CRC8D	0xnn	

Table 61

In this case, the following **RESPONSE** message gives the return codes:

00 RET\_OK  
 02 RET\_NOT\_SUPPORTED  
 03 RET\_WRONG\_PARAM

Since no additional data are included which require description the standard RESPONSE structure is detailed in chapter 1.8.3

## 1.13 Packet Type 7: REMOTE\_MAN\_COMMAND

### 1.13.1 Structure

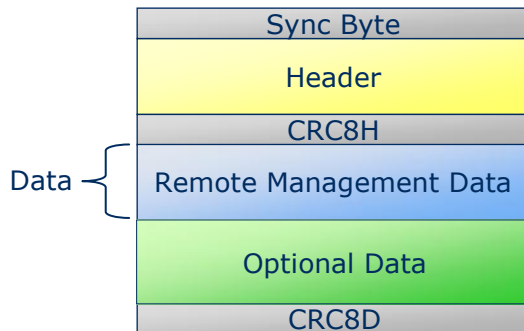

Figure 12

This section describes the remote management command structure. This structure is applied for the send as well as the receive case.

### 1.13.2 Description

Function: Remote Management send or receive message.

Group	Offset	Size	Field	Value hex	Description
-	0	1	Sync. Byte	0x55	
Header	1	2	Data Length	0xnxxx	4 + x bytes
	3	1	Optional Length	0x00	10 bytes
	4	1	Packet Type	0x07	REMOTE_MAN_COMMAND = 7
-	5	1	CRC8H	0xnn	
Data	6	2	Function No.	0x0xxx	Range: 0x0000 ... 0x0FFF
	8	2	Manufacturer ID	0x0xxx	Range: 0x0000 ... 0x07FF
	10	x	Message data	...	0 ... 511 bytes
Optional Data	10+x	4	Destination ID	0xxxxxxxx	Destination ID Broadcast ID: FF FF FF FF
	14+x	4	Source ID	0xxxxxxxx	Receive case: Source ID of the sender Send case: 0x00000000
	18+x	1	dBm	0xnn	Send case: 0xFF Receive case: Best RSSI value of all received sub telegrams (value decimal without minus)
	19+x	1	Send With Delay	0x0n	1: if the first message has to be sent with random delay. When answering to broadcast message this has to be 1, otherwise 0. Default: 0
-	20+x	1	CRC8D	0xnn	CRC8 <u>D</u> ata byte; calculated checksum for whole byte groups: DATA and OPTIONAL_DATA

Table 62

The receive case has no RESPONSE.

## EnOcean Serial Protocol 3 (ESP3)

The send case has the following **RESPONSE** with the return codes:

00 RET\_OK  
02 RET\_NOT\_SUPPORTED  
03 RET\_WRONG\_PARAM

Since no additional data are included, which require description the standard RESPONSE structure is detailed in chapter 1.8.3

## 2 Appendix

### 2.1 ESP3 Data flow sequences

The following examples illustrate the ESP3 traffic. In particular the flow of the Smart Ack commands is more complex.

#### 2.1.1 Client data request

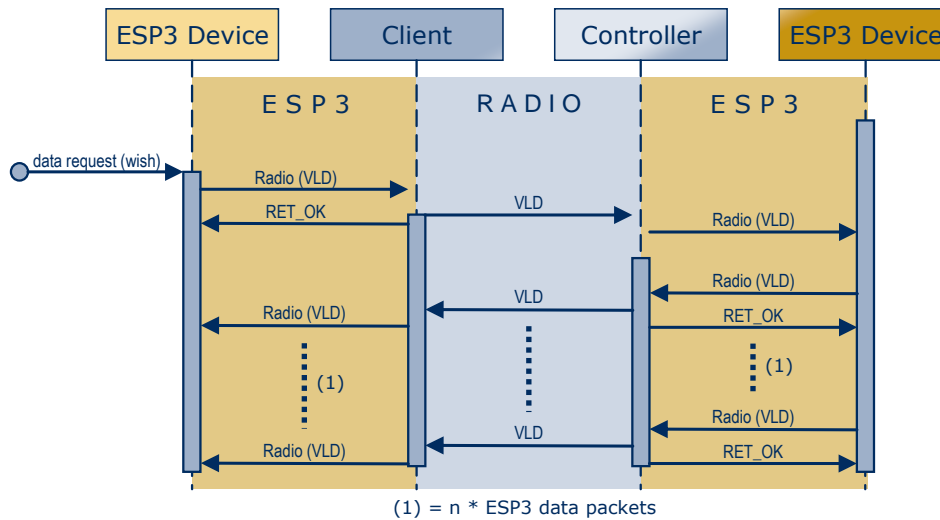

Figure 13

#### 2.1.2 Teach IN via VLL

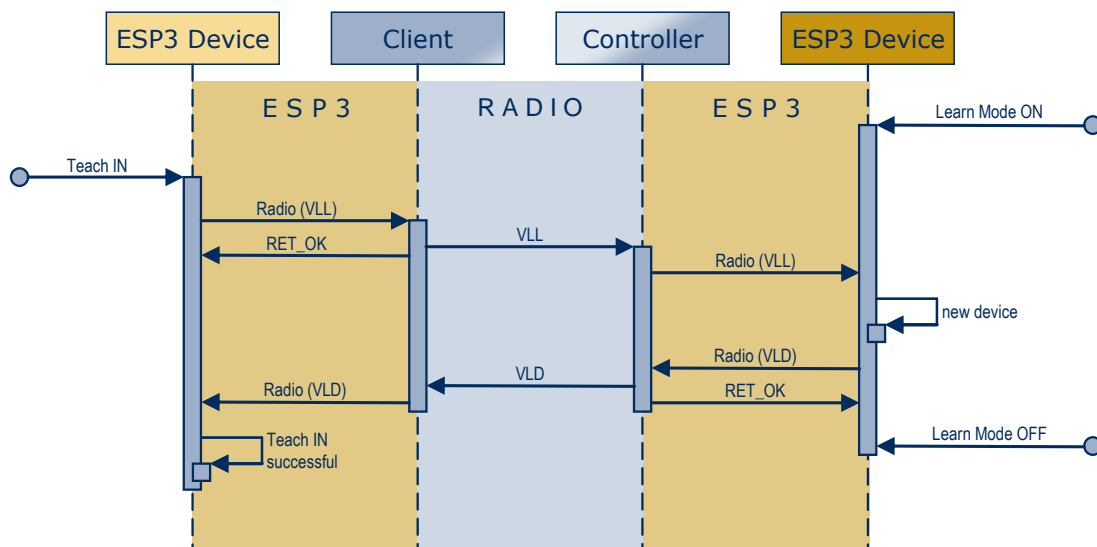
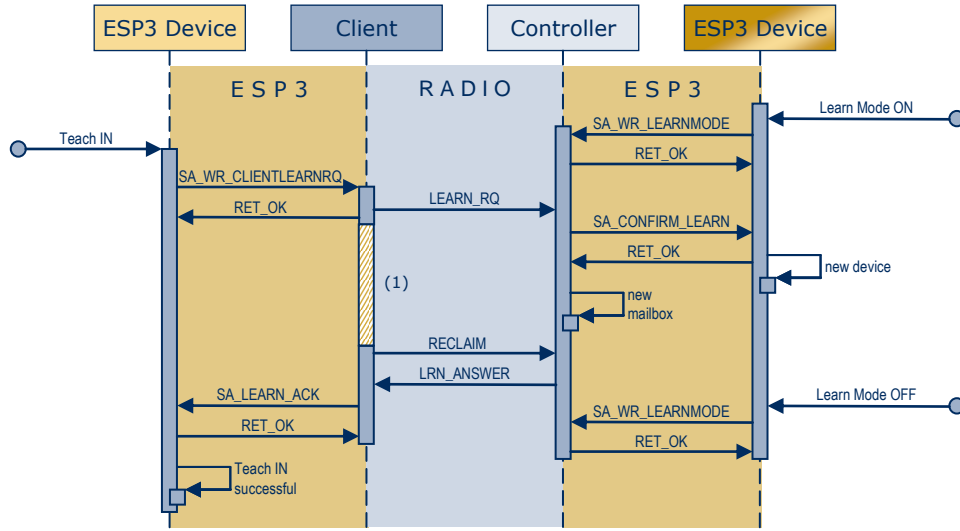

Figure 14

### 2.1.3 Teach IN via Smart Ack



(1) = Short Term Sleep

Figure 15

### 2.1.4 Teach IN via Smart Ack incl. repeater

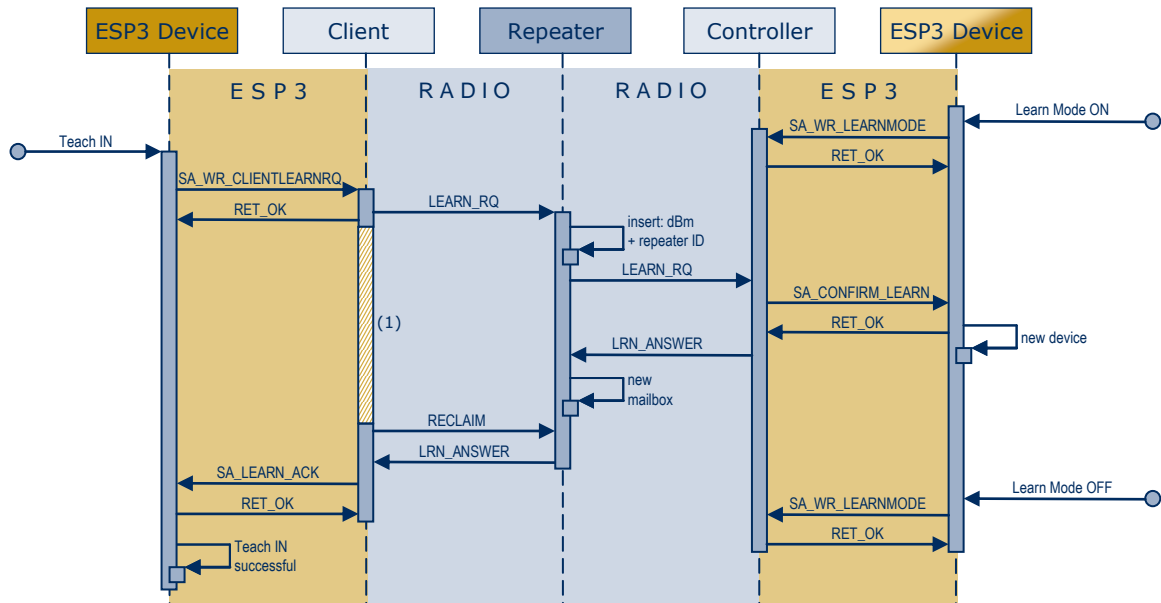

(1) = Short Term Sleep

Figure 16

## 2.2 ESP3 telegram examples

### 2.2.1 Packet: Radio VLD

Sy	Header	CR C8	Data	Optional Data	CR C8
55	00 0F 07 01	2B	D2 DD DD DD DD DD DD DD DD DD 00 80 35 C4 00	03 FF FF FF FF 4D 00	36

### 2.2.2 Packet: CO\_WR\_SLEEP

Sy	Header	CR C8	Data	CR C8
55	00 05 00 05	DB	01 00 00 00 0A	54

Periode = 10 (0x0A)

### 2.2.3 Packet: CO\_WR\_RESET

Sy	Header	CR C8	Data	CR C8
55	00 01 00 05	70	02	0E

### 2.2.4 Packet: CO\_RD\_IDBASE

Sy	Header	CR C8	Data	CR C8
55	00 01 00 05	70	08	38

Response RET\_OK:

Sy	Header	CR C8	Data	CR C8
55	00 05 00 02	CE	00 FF 80 00 00	DA

### 2.2.5 Packet: REMOTE\_MAN\_COMMAND

Example dummy command:

Function = 0x1212  
 Manufacture = 0x07FF  
 DestinationID = 0xFFFFFFFF  
 SendWithDelay = 0

Sy	Header	CR C8	Data	CR C8
55	00 19 00 07	8D	12 12 07 FF FF FF FF FF 00 00 01 02 03 04 05 06 07 08 09 0A 0B 0C 0D 0E 0F	DA

Example QueryID:

Sy	Header	CR C8	Data	CR C8
55	00 0C 00 07	EF	00 04 07 FF FF FF FF FF 00 00 00 00	65

## 2.3 CRC8 calculation

The polynomial  $G(x) = x^8 + x^2 + x^1 + x^0$  is used to generate the CRC8 table, needed for the CRC8 calculation. Following C code illustrates how the CRC8 value is calculated:

### Implementation:

```
uint8 u8CRC8Table[256] = {
    0x00, 0x07, 0x0e, 0x09, 0x1c, 0x1b, 0x12, 0x15,
    0x38, 0x3f, 0x36, 0x31, 0x24, 0x23, 0x2a, 0x2d,
    0x70, 0x77, 0x7e, 0x79, 0x6c, 0x6b, 0x62, 0x65,
    0x48, 0x4f, 0x46, 0x41, 0x54, 0x53, 0x5a, 0x5d,
    0xe0, 0xe7, 0xee, 0xe9, 0xfc, 0xfb, 0xf2, 0xf5,
    0xd8, 0xdf, 0xd6, 0xd1, 0xc4, 0xc3, 0xca, 0xcd,
    0x90, 0x97, 0x9e, 0x99, 0x8c, 0x8b, 0x82, 0x85,
    0xa8, 0xaf, 0xa6, 0xa1, 0xb4, 0xb3, 0xba, 0xbd,
    0xc7, 0xc0, 0xc9, 0xce, 0xdb, 0xdc, 0xd5, 0xd2,
    0xff, 0xf8, 0xf1, 0xf6, 0xe3, 0xe4, 0xed, 0xea,
    0xb7, 0xb0, 0xb9, 0xbe, 0xab, 0xac, 0xa5, 0xa2,
    0x8f, 0x88, 0x81, 0x86, 0x93, 0x94, 0x9d, 0x9a,
    0x27, 0x20, 0x29, 0x2e, 0x3b, 0x3c, 0x35, 0x32,
    0x1f, 0x18, 0x11, 0x16, 0x03, 0x04, 0x0d, 0x0a,
    0x57, 0x50, 0x59, 0x5e, 0x4b, 0x4c, 0x45, 0x42,
    0x6f, 0x68, 0x61, 0x66, 0x73, 0x74, 0x7d, 0x7a,
    0x89, 0x8e, 0x87, 0x80, 0x95, 0x92, 0x9b, 0x9c,
    0xb1, 0xb6, 0xbf, 0xb8, 0xad, 0xaa, 0xa3, 0xa4,
    0xf9, 0xfe, 0xf7, 0xf0, 0xe5, 0xe2, 0xeb, 0xec,
    0xc1, 0xc6, 0xcf, 0xc8, 0xdd, 0xda, 0xd3, 0xd4,
    0x69, 0x6e, 0x67, 0x60, 0x75, 0x72, 0x7b, 0x7c,
    0x51, 0x56, 0x5f, 0x58, 0x4d, 0x4a, 0x43, 0x44,
    0x19, 0x1e, 0x17, 0x10, 0x05, 0x02, 0x0b, 0x0c,
    0x21, 0x26, 0x2f, 0x28, 0x3d, 0x3a, 0x33, 0x34,
    0x4e, 0x49, 0x40, 0x47, 0x52, 0x55, 0x5c, 0x5b,
    0x76, 0x71, 0x78, 0x7f, 0x6a, 0x6d, 0x64, 0x63,
    0x3e, 0x39, 0x30, 0x37, 0x22, 0x25, 0x2c, 0x2b,
    0x06, 0x01, 0x08, 0x0f, 0x1a, 0x1d, 0x14, 0x13,
    0xae, 0xa9, 0xa0, 0xa7, 0xb2, 0xb5, 0xbc, 0xbb,
    0x96, 0x91, 0x98, 0x9f, 0x8a, 0x8d, 0x84, 0x83,
    0xde, 0xd9, 0xd0, 0xd7, 0xc2, 0xc5, 0xcc, 0xcb,
    0xe6, 0xe1, 0xe8, 0xef, 0xfa, 0xfd, 0xf4, 0xf3
};

#define proccrc8(u8CRC, u8Data) (u8CRC8Table[u8CRC ^ u8Data])
```

### Example:

```
u8CRC = 0;
for (i = 0 ; i < u16DataSize ; i++)
    u8CRC = proccrc8(u8CRC, u8Data[i]);
printf("CRC8 = %02X\n", u8CRC);
```

## 2.4 UART Synchronization (example c-code)

### 2.4.1 ESP3 Packet Structure

```

//! Packet structure (ESP3)
typedef struct
{
    // Amount of raw data bytes to be received. The most significant byte is sent/received first
    uint16_t u16DataLength;
    // Amount of optional data bytes to be received
    uint8_t u8OptionLength;
    // Packet type code
    uint8_t u8Type;
    // Data buffer: raw data + optional bytes
    uint8_t *u8DataBuffer;
} PACKET_SERIAL_TYPE;

```

### 2.4.2 Get ESP3 Packet

```

//! \file uart_getPacket.c
#include "EO3000I_API.h"
#include "proc.h"
#include "uart.h"
#include "time.h"

/*
ESP3 packet structure through the serial port.

Protocol bytes are generated and sent by the application

Sync = 0x55
CRC8H
CRC8D

      1           2           1           1           1           u16DataLen + u8OptionLen           1
+-----+-----+-----+-----+-----+-----+-----+-----+-----+
| 0x55 | u16DataLen | u8OptionLen | u8Type | CRC8H |          DATAS          | CRC8D |
+-----+-----+-----+-----+-----+-----+-----+-----+

DATAS structure:

                u16DataLen                u8OptionLen
+-----+-----+-----+-----+-----+-----+
|          Data          |          Optional          |
+-----+-----+-----+-----+-----+
*/

RETURN_TYPE uart_getPacket(PACKET_SERIAL_TYPE *pPacket, uint16_t u16BufferLength)
{
    //! uart_getPacket state machine states.
    typedef enum
    {
        //! Waiting for the synchronisation byte 0x55
        GET_SYNC_STATE=0,
        //! Copying the 4 after sync byte: raw data length (2 bytes), optional data length (1), type (1).
        GET_HEADER_STATE,
        //! Checking the header CRC8 checksum. Resynchronisation test is also done here
        CHECK_CRC8H_STATE,
        //! Copying the data and optional data bytes to the packet buffer
        GET_DATA_STATE,
        //! Checking the info CRC8 checksum.
        CHECK_CRC8D_STATE,
    } STATES_GET_PACKET;

    //! UART received byte code

```



## Appendix

```

uint8  u8RxByte;
//! Checksum calculation
static uint8 u8CRC = 0;
//! Nr. of bytes received
static uint16 u16Count = 0;
//! State machine counter
static STATES_GET_PACKET u8State = GET_SYNC_STATE;
//! Timeout measurement
static uint8 u8TickCount = 0;
// Byte buffer pointing at the packet address
uint8 *u8Raw = (uint8*)pPacket;
// Temporal variable
uint8  i;

// Check for timeout between two bytes
if (((uint8)ug32SystemTimer) - u8TickCount > SER_INTERBYTE_TIME_OUT)
{
    // Reset state machine to init state
    u8State = GET_SYNC_STATE;
}

// State machine goes on when a new byte is received
while (uart_getByte(&u8RxByte) == OK)
{
    // Tick count of last received byte
    u8TickCount = (uint8)ug32SystemTimer;

    // State machine to load incoming packet bytes
    switch(u8State)
    {
        // Waiting for packet sync byte 0x55
        case GET_SYNC_STATE:

            if (u8RxByte == SER_SYNCH_CODE)
            {
                u8State = GET_HEADER_STATE;
                u16Count = 0;
                u8CRC = 0;
            }

            break;

        // Read the header bytes
        case GET_HEADER_STATE:

            // Copy received data to buffer
            u8Raw[u16Count++] = u8RxByte;
            u8CRC = proc_crc8(u8CRC, u8RxByte);

            // All header bytes received?
            if(u16Count == SER_HEADER_NR_BYTES)
            {
                u8State = CHECK_CRC8H_STATE;
            }

            break;

        // Check header checksum & try to resynchronise if error happened
        case CHECK_CRC8H_STATE:

            // Header CRC correct?
            if (u8CRC != u8RxByte)
            {
                // No. Check if there is a sync byte (0x55) in the header
                int a = -1;
                for (i = 0 ; i < SER_HEADER_NR_BYTES ; i++)
                    if (u8Raw[i] == SER_SYNCH_CODE)
                    {
                        // indicates the next position to the sync byte found
                        a=i+1;
                        break;
                    }
            }

            if ((a == -1) && (u8RxByte != SER_SYNCH_CODE))
            {
                // Header and CRC8H does not contain the sync code
            }
        }
    }

```

```

        u8State = GET_SYNC_STATE;
        break;
    }
else if((a == -1) && (u8RxByte == SER_SYNCH_CODE))
{
    // Header does not have sync code but CRC8H does.
    // The sync code could be the beginning of a packet
    u8State = GET_HEADER_STATE;
    u16Count = 0;
    u8CRC = 0;
    break;
}

// Header has a sync byte. It could be a new telegram.
// Shift all bytes from the 0x55 code in the buffer.
// Recalculate CRC8 for those bytes
u8CRC = 0;
for (i = 0 ; i < (SER_HEADER_NR_BYTES - a) ; i++)
{
    u8Raw[i] = u8Raw[a+i];
    u8CRC = proc_crc8(u8CRC, u8Raw[i]);
}
u16Count = SER_HEADER_NR_BYTES - a;
// u16Count = i; // Seems also valid and more intuitive than u16Count -= a;

// Copy the just received byte to buffer
u8Raw[u16Count++] = u8RxByte;
u8CRC = proc_crc8(u8CRC, u8RxByte);

if(u16Count < SER_HEADER_NR_BYTES)
{
    u8State = GET_HEADER_STATE;
    break;
}

break;
}

// CRC8H correct. Length fields values valid?
if((pPacket->u16DataLength + pPacket->u8OptionLength) == 0)
{
    //No. Sync byte received?
    if((u8RxByte == SER_SYNCH_CODE))
    {
        //yes
        u8State = GET_HEADER_STATE;
        u16Count = 0;
        u8CRC = 0;
        break;
    }

    // Packet with correct CRC8H but wrong length fields.
    u8State = GET_SYNC_STATE;
    return OUT_OF_RANGE;
}

// Correct header CRC8. Go to the reception of data.
u8State = GET_DATA_STATE;
u16Count = 0;
u8CRC = 0;

break;

// Copy the information bytes
case GET_DATA_STATE:

    // Copy byte in the packet buffer only if the received bytes have enough room
    if(u16Count < u16BufferLength)
    {
        pPacket->u8DataBuffer[u16Count] = u8RxByte;
        u8CRC = proc_crc8(u8CRC, u8RxByte);
    }

    // When all expected bytes received, go to calculate data checksum
    if( ++u16Count == (pPacket->u16DataLength + pPacket->u8OptionLength) )
    {
        u8State = CHECK_CRC8D_STATE;
    }
}

```

```
    }  
    break;  
  
    // Check the data CRC8  
    case CHECK_CRC8D_STATE:  
        // In all cases the state returns to the first state: waiting for next sync byte  
        u8State = GET_SYNC_STATE;  
  
        // Received packet bigger than space to allocate bytes?  
        if (u16Count > u16BufferLength) return OUT_OF_RANGE;  
  
        // Enough space to allocate packet. Equals last byte the calculated CRC8?  
        if (u8CRC == u8RxByte) return OK; // Correct packet received  
  
        // False CRC8.  
        // If the received byte equals sync code, then it could be sync byte for next packet.  
        if ((u8RxByte == SER_SYNCH_CODE))  
        {  
            u8State = GET_HEADER_STATE;  
            u16Count = 0;  
            u8CRC = 0;  
        }  
  
        return NOT_VALID_CHKSUM;  
  
    default:  
        // Yes. Go to the reception of info.  
        u8State = GET_SYNC_STATE;  
        break;  
    }  
}  
return (u8State == GET_SYNC_STATE) ? NO_RX_TEL : NEW_RX_BYTE;  
}
```

### 2.4.3 Send ESP3 Packet

```

/*! \file uart_sendPacket.c

#include "EO3000I_API.h"
#include "proc.h"
#include "uart.h"

/*
ESP3 packet structure through the serial port.

Protocol bytes are generated and sent by the application

Sync = 0x55
CRC8H
CRC8D

      1           2           1           1           1           u16DataLen + u8OptionLen           1
+-----+-----+-----+-----+-----+-----+-----+-----+
| 0x55 | u16DataLen | u8OptionLen | u8Type | CRC8H | DATAS | CRC8D |
+-----+-----+-----+-----+-----+-----+-----+

DATAS structure:

                        u16DataLen           u8OptionLen
+-----+-----+-----+-----+-----+-----+
|           Data           | Optional |
+-----+-----+-----+-----+-----+

*/

RETURN_TYPE uart_sendPacket(PACKET_SERIAL_TYPE *pPacket)
{
    uint16 i;
    uint8  u8CRC;

    // When both length fields are 0, then this telegram is not allowed.
    if((pPacket->u16DataLength || pPacket->u8OptionLength) == 0)
    {
        return OUT_OF_RANGE;
    }
    // Sync
    while(uart_sendByte(0x55) != OK);

    // Header
    while(uart_sendBuffer((uint8*)pPacket, 4) != OK);

    // Header CRC
    u8CRC = 0;
    u8CRC = proc_crc8(u8CRC, ((uint8*)pPacket)[0]);
    u8CRC = proc_crc8(u8CRC, ((uint8*)pPacket)[1]);
    u8CRC = proc_crc8(u8CRC, ((uint8*)pPacket)[2]);
    u8CRC = proc_crc8(u8CRC, ((uint8*)pPacket)[3]);
    while(uart_sendByte(u8CRC) != OK);

    // Data
    u8CRC = 0;
    for (i = 0 ; i < (pPacket->u16DataLength + pPacket->u8OptionLength) ; i++)
    {
        u8CRC = proc_crc8(u8CRC, pPacket->u8DataBuffer[i]);
        while(uart_sendByte(pPacket->u8DataBuffer[i]) != OK);
    }

    // Data CRC
    while(uart_sendByte(u8CRC) != OK);

    return OK;
}

```